

Integra

Version : 1.6
Date : March 2002
Reference : WM_Integra_UG_016

Integra

Level/ Indice	Date/ Date	History of the evolution / Historique des évolutions	Writer / Rédacteur
0.3	June 2000	Creation and Correction	P. Calvez, S. Dechicha F. Doherier, T. Lapousterle, M. Nau, D. Martinez, B. Zenou
1.2	Sept. 2000	Correction: figure 5 application note for serial link	S. Dechicha
1.3	Sept 2000	Application note for external SIM 3V/5V interface	S. Dechicha
1.4	January 2001	Minor formal modifications + addition of the mechanical specifications	M. Nau
1.5	August 2001	SIM3/5V electric scheme added + modification flat cable reference	S. Marion
1.6	March 2002	Modifications to include 2C-2 module version	N. Subiger

	Name / Nom	Function / Fonction	Date/ Date	Signature/ Signature
Written by / Rédigé par	Nsu	Product Marketing	March 02	
Validated by / Validé par	Pjs / Rla	Modem Support Engineer	March 02	
Approved by / Approuvé par	Pde	Product Marketing Senior Manager	March 02	

**Integra User's Guide
Hardware Specifications**



Contents

1	Introduction to the Integra: outstanding assets	7
1.1	Scope of the user's guide	7
1.2	General characteristics.....	8
1.2.1	General	8
1.2.2	Electrical	8
1.2.3	Physical	8
1.2.4	Basic Features	8
1.2.5	Interfaces	9
1.3	Mechanical Design Overview.....	10
2	Safety precautions	13
2.1	RF safety	13
2.1.1	General	13
2.1.2	Exposure to RF energy	13
2.1.3	Efficient modem operation	13
2.1.4	Antenna care and replacement	14
2.2	General safety.....	15
2.2.1	Driving	15
2.2.2	Electronic devices	15
2.2.3	Vehicle electronic equipment	15
2.2.4	Medical electronic equipment	15
2.2.5	Aircraft.....	15
2.2.6	Children	15
2.2.7	Blasting areas	16
2.2.8	Potentially explosive atmospheres	16
2.3	Safety standards.....	16
3	Standard Compliance.....	16
3.1	GSM compliance	16
3.2	FTA Compliance	17
3.2.1	IMEI Number	17
3.2.2	CE Label.....	18
4	Hardware Interfaces.....	19
4.1	Interfaces on the 50-pin general purpose connector	19
4.1.1	The 50-pin connector description.....	19
4.1.2	Power supply	23
4.1.3	Serial link	25
4.1.4	ON / ~OFF	26
4.1.5	BOOT.....	28
4.1.6	Reset signal (~RST)	29

Integra

4.1.7	Flashing LED.....	30
4.1.8	General Purpose Input/Output.....	31
4.1.9	Analog to Digital Converter.....	31
4.1.10	Audio Interface.....	33
4.1.11	SIM interface.....	37
4.1.12	SPI bus.....	39
4.1.13	Keypad interface.....	39
4.2	RF Interface.....	41
4.2.1	RF connector.....	41
4.2.2	RF performances.....	41
4.3	SIM interface.....	41
5	Connector Supplier and Peripheral devices.....	42
5.1	Where to find the SMD connectors.....	42
5.1.1	GSM Antenna.....	43
5.1.2	The SIM card holder.....	44
6	Climatic and mechanical environment.....	44
7	Demonstration board.....	45
8	General guidelines for the use of the Integra.....	46
8.1	Key information.....	46
8.1.1	Hardware and RF.....	46
8.1.2	The Antenna.....	46
8.1.3	Firmware upgrade.....	46
8.1.4	Getting started.....	47
9	Reference documents.....	49
10	Acronyms and Abbreviations.....	50
11	Index.....	51
12	Appendix 1.....	55
12.1	Mechanical specifications.....	55
12.2	3V/5V SIM management.....	56
12.3	AT command list.....	56
12.4	Connectors data sheet.....	61
13	Appendix 2.....	64
13.1	RF Exposures.....	64
13.2	Instructions to OEM.....	64

Cautions:

Information furnished herein by Wavecom are accurate and reliable. However no responsibility is assumed for its use.
Please read carefully the safety precautions.

If you have any technical questions regarding this document or the product described in it, please contact your distributor.
General information about Wavecom and its range of products is available at the following internet address: <http://www.wavecom.com>

Trademarks

Some mentioned products are registered trademarks of their respective companies

Copyright

The Integra user's guide is copyrighted by Wavecom SA with all rights reserved. No part of this user's guide may be produced in any form without the prior written permission of Wavecom SA.

No patent liability is assumed with respect to the use of the information contained herein.

1 Introduction to the Integra: outstanding assets

Integra M2100 series integrated modem provides a quick and easy way to plug in GSM and GPRS functionality to systems and terminals. Available in dual-band configurations, this full type approved integrated modem constitutes a self-contained, fully integrated implementation of the GSM/GPRS standard.

Thanks to standard interfaces, it can be integrated into any system which offers unlimited assets. It is ready for voice, SMS, data and fax. Integra is a product with a sole connector, which puts together all the interface signals in order to facilitate its integration.

It has an integrated SIM connector as well as a standard RF connector type MMCX (Miniature Micro Connector).

For system integrators, Integra is the fast track to the wireless world.

1.1 Scope of the user's guide

This document describes the hardware interface and the technical specifications of the Integra M2100 series modem.

The integrated modem is referenced as Integra according to the GSM/GPRS 900 standard, the GSM/GPRS 1800 standard and the GSM/GPRS 1900 standard. This product is based on a Dual Band WISMO[™]; every integrated modem referenced Integra-G900/1800 includes a GSM 900/1800 MHz module and every integrated modem referenced Integra-G900/1900 includes a GSM 900/1900 MHz module. This two dual-band modems have the same specifications unless otherwise specified.

Integra has two versions, one GSM only and one GSM/GPRS.

The GSM only version is based on a WISMO 2C.

The GSM / GPRS version is based on a WISMO 2C-2.

1.2 General characteristics

1.2.1 General

- Dual Band GSM/GPRS modem E-GSM 900/1800 or E-GSM 900/1900
- Class 4 (2W at 900MHz)
- Class 1 (1W at 1800/1900 MHz)
- Small size and low power consumption
- Voice, SMS
- fax and data transmission without extra hardware
- Tricodec (FR/EFR/HR)
- Internal 3V SIM interface
- Easy remote control by AT commands for dedicated applications
- Fully Type Approved according to GSM Phase 2+ specifications
- Fully shielded and ready-to-use

1.2.2 Electrical

- Power supply: 5 VDC +/- 5% 1A
- 310 mA average in GSM 900 at Tx power max 2W
- 410 mA average in GSM/GRPS 900 at Tx power max 2W
- 9 mA in idle mode

1.2.3 Physical

- Absolute maximum dimension: 46 x 64 x 12 mm
- Weight: 90 g
- Volume: 36.21 cm³
- Casing: Complete shielding-stainless steel-
- Mounting: 4 screw holes
- Operating temperature range: -20°C to + 55°C
- Storage temperature: -35°C to +85°C

1.2.4 Basic Features

1.2.4.1 telephony

- Telephony (TCH/FS) & Emergency calls
- Full Rate, Enhanced Full Rate and Half Rate
- Dual Tone Multi Frequency function (DTMF)

Integra

1.2.4.2 Short Message Service (GSM and GPRS mode)

- Text and PDU
- Point to point MT & MO
- SMS Cell Broadcast

1.2.4.3 GSM circuit Data Features

- Data circuit asynchronous, transparent and non transparent up to 14,400 bits/s
- Automatic fax group 3 (Class 1 & 2)
- Alternate speech and fax
- MNP2, V.42bis

1.2.4.4 GPRS Packet Data Features

- GPRS Class 2
- Coding Schemes: C1S1 to CS4
- Compliant with SMG31bis

1.2.4.5 GSM Supplementary services

- Call Forwarding
- Call Barring
- Multiparty
- Call Waiting and Call Hold
- Calling Line Identity
- Advice of Charge
- USSD
- Closed User Group
- Explicit Call Transfer

1.2.4.6 Other features

- ME+SIM phone book management
- Fixed Dialling Number
- SIM Toolkit Class 2
- SIM, network and service provider locks
- Real Time Clock
- Alarm management
- Software upgrade through Xmodem protocol
- UCS2 character set management

1.2.5 Interfaces

Single antenna interface

Internal SIM interface: 3V only

External SIM interface: 3V only for engineering sample.
3V or 5V for production unit

For Data Operation:

RS-232C serial link

remote control by AT commands (GSM 07.07 and 07.05)

baud rate from 300 to 115,200 bits/s

from 300 up to 38400 bits/s with autobauding

Integra

1.3 Mechanical Design Overview

Integra is encased as shown in the figure here-below. It includes a WISMO™ module, a 50-pin connector, a SIM holder and a RF connector.

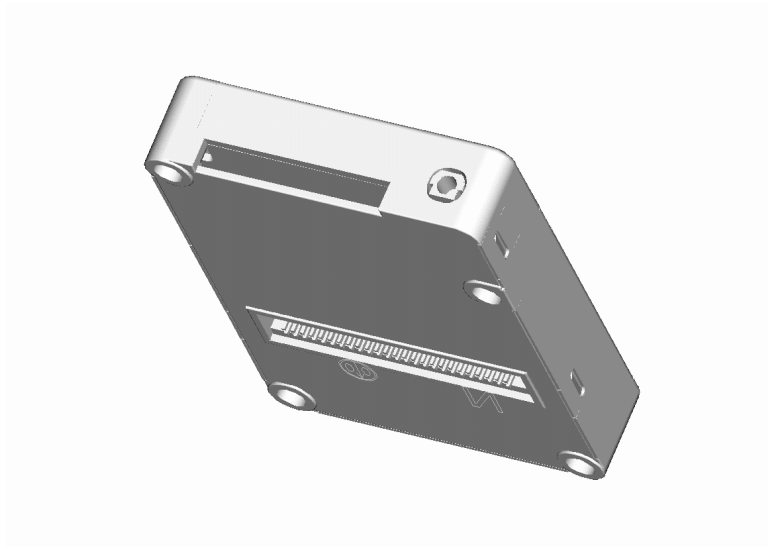

figure 1 : mechanical description

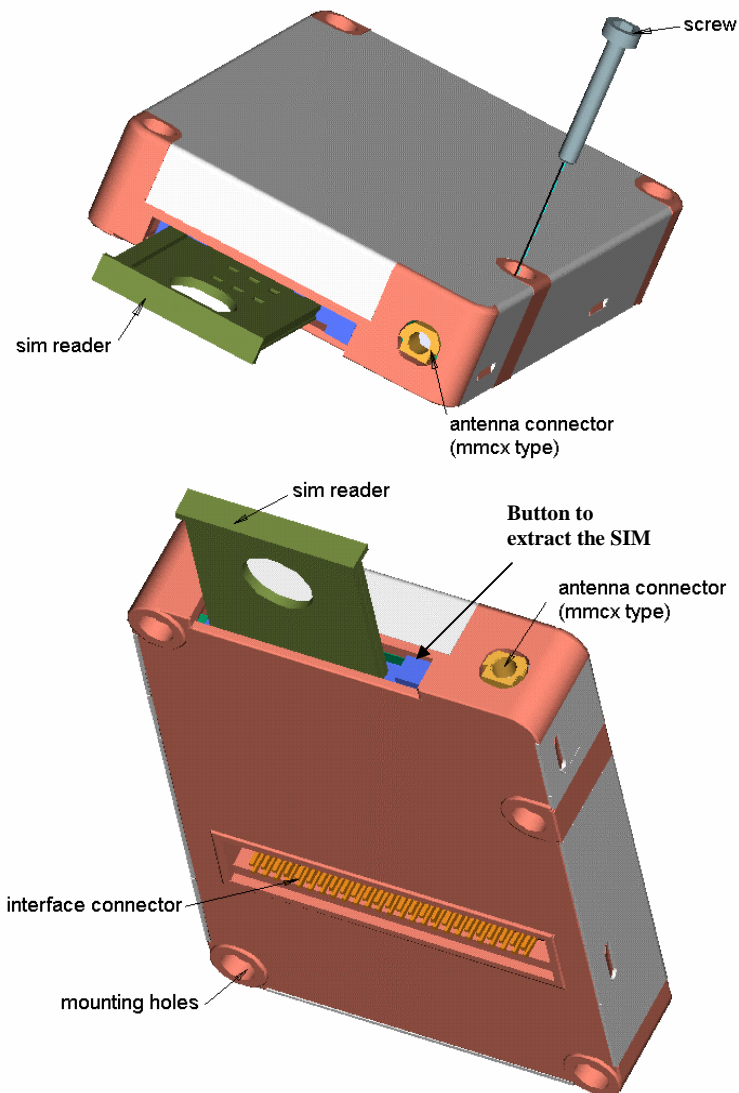

figure 2 : mechanical description II

4 screw holes allow the Integra to be fixed on the mother PCB. The Integra can be mounted indifferently on both sides (top or bottom).
For further details [see mechanical specifications in annex.](#)

Integra

Note: Interfaces

The integrated modem has a sole 50-pin connector which gathers all the interface signals in order to facilitate its integration.

It has an integrated SIM card holder as well as a standard RF connector type MMCX (Miniature Micro Connector)

The concept of the integrated modem has been defined to integrate on a sole device:

- only one standard easy to find connector (worldwide supplied) gathering the analog and digital interfaces
- one standard easy to find RF connector. See chapter RF connector page 34
- one SIM card holder. See chapter SIM interface

2 Safety precautions

**IMPORTANT
FOR THE EFFICIENT AND SAFE OPERATION OF
YOUR GSM INTEGRATED MODEM
READ THIS INFORMATION BEFORE USE**

2.1 RF safety

2.1.1 General

Your Integra modem is based on the GSM standard for cellular technology. The GSM standard is spread all over the world. It covers Europe, Asia and some parts of America and Africa. This is the most used telecommunication standard.

Your modem is actually a low power radio transmitter and receiver. It sends out and receives radio frequency energy. When you use your Integra integrated modem, the cellular system which handles your calls controls both the radio frequency and the power level of your cellular modem.

2.1.2 Exposure to RF energy

There has been some public concern about possible health effects of using GSM modems. Although research on health effects from RF energy has focused on the current RF technology for many years, scientists have begun research regarding newer radio technologies, such as GSM. After existing research had been reviewed, and after compliance to all applicable safety standards had been tested, it has been concluded that the product was fitted for use.

If you are concerned about exposure to RF energy there are things you can do to minimize exposure. Obviously, limiting the duration of your calls will reduce your exposure to RF energy. In addition, you can reduce RF exposure by operating your cellular modem efficiently by following the below guidelines.

2.1.3 Efficient modem operation

For your modem to operate at the lowest power level, consistent with satisfactory call quality :

If your modem has an extendible antenna, extend it fully. Some models allow you to place a call with the antenna retracted. However your modem operates more efficiently with the antenna fully extended.

Do not hold the antenna when the modem is « IN USE ». Holding the antenna affects call quality and may cause the modem to operate at a higher power level than needed.

Integra

2.1.4 Antenna care and replacement

Do not use the modem with a damaged antenna. If a damaged antenna comes into contact with the skin, a minor burn may result. Replace a damaged antenna immediately. Consult your manual to see if you may change the antenna yourself. If so, use only a manufacturer-approved antenna. Otherwise, have your antenna repaired by a qualified technician.

Use only the supplied or approved antenna. Unauthorized antennas, modifications or attachments could damage the modem and may contravene local RF emission regulations or invalidate type approval.

2.2 General safety

2.2.1 Driving

Check the laws and the regulations regarding the use of cellular devices in the area where you have to drive as you always have to comply with them. When using your modem while driving, please :

- give full attention to driving,
- pull off the road and park before making or answering a call if driving conditions so require.

2.2.2 Electronic devices

Most electronic equipment, for example in hospitals and motor vehicles is shielded from RF energy. However RF energy may affect some improperly shielded electronic equipment.

2.2.3 Vehicle electronic equipment

Check your vehicle manufacturer representative to determine if any on-board electronic equipment is adequately shielded from RF energy.

2.2.4 Medical electronic equipment

Consult the manufacturer of any personal medical devices (such as pacemakers, hearing aids, etc...) to determine if they are adequately shielded from external RF energy.

Turn your modem OFF in health care facilities when any regulations posted in the area instruct you to do so. Hospitals or health care facilities may be using RF monitoring equipment.

2.2.5 Aircraft

Turn your modem OFF before boarding any aircraft.

- Use it on the ground only with crew permission.
- Do not use it in the air.

To prevent possible interference with aircraft systems, Federal Aviation Administration (FAA) regulations require you to have permission from a crew member to use your modem while the aircraft is on the ground. To prevent interference with cellular systems, local RF regulations prohibit using your modem while airborne.

2.2.6 Children

Do not allow children to play with your modem. It is not a toy. Children could hurt themselves or others (by poking themselves or others in the eye with the antenna, for example). Children could damage the modem, or make calls that increase your modem bills.

Integra

2.2.7 Blasting areas

To avoid interfering with blasting operations, turn your unit OFF when in a « blasting area » or in areas posted : « turn off two-way radio ». Construction crew often use remote control RF devices to set off explosives.

2.2.8 Potentially explosive atmospheres

Turn your modem OFF when in any area with a potentially explosive atmosphere. It is rare, but your modem or its accessories could generate sparks. Sparks in such areas could cause an explosion or fire resulting in bodily injuries or even death.

Areas with a potentially explosive atmosphere are often, but not always, clearly marked. They include fueling areas such as petrol stations ; below decks on boats ; fuel or chemical transfer or storage facilities ; and areas where the air contains chemicals or particles, such as grain, dust, or metal powders.

Do not transport or store flammable gas, liquid, or explosives, in the compartment of your vehicle which contains your modem or accessories.

Before using your modem in a vehicle powered by liquefied petroleum gas (such as propane or butane) ensure that the vehicle complies with the relevant fire and safety regulations of the country in which the vehicle is to be used.

2.3 Safety standards

THIS INTEGRA COMPLIES WITH ALL APPLICABLE RF SAFETY STANDARDS.

This cellular modem meets the standards and recommendations for the protection of public exposure to RF electromagnetic energy established by governmental bodies and other qualified organizations, such as the following :

Directives of the European Community, Directorate General V in Matters of Radio Frequency Electromagnetic Energy

3 Standard Compliance

3.1 GSM compliance

Reference regulations: TBR 19, TBR 20, TBR 31, TBR 32

Table 1 : Wavecom acceptance test

Tests	Applied Standard	Acceptance Criteria
Performance Test	ETSI recommendation for GSM/DCS communication.	Full conformity to the recommendation regarding the main RF parameters.
Cooking Test	-	The test continues even after the Cooking Test milestone has been reached
Stress Test	Therma shocks IEC 68-2-14.	Full conformity to the recommendation regarding the main parameters.
Vibration Test	Sinusoidal vibration IEC 68-2-6.	No performance degradation or mechanical degradation is allowed after test.

Vibration Test	Random vibration IEC 68-2-36.	No performance degradation or mechanical degradation is allowed after test.
Shock Test	IEC 68-2-27.	No performance degradation or mechanical degradation is allowed after test.
Bump Test	IEC 68-2-29.	No performance degradation or mechanical degradation is allowed after test.
Humidity Test	Corrosion test IEC 68-2-3.	No visible degradation of the product, both visual and functional. The unit is tested at room temperature and must be fully operative for the main RF parameters.
Warehouse Test	Low temperature IEC 68-2-1.	Under normal condition (room temperature) after the test, the unit must behave in full conformity with the main RF parameters specification.
Warehouse Test	High temperature IEC 68-2-2.	Under normal condition (room temperature) after the test, the unit must behave in full conformity with the main RF parameters specification.
Dust Test	MIL-STD-810D, method 510-3.	No visible dust in the visible areas. No more than 50 dust particules in the cabinet of the product. The unit, tested at room temperature must be fully operative.
Light Test	UV radiation and temperature EDF HN60E03.	Visual inspection on the discoloration and other degradation effects such as cracks in the material of the unit after the test.
Fall Test	IEC 68-2-32.	Only minor casing degradation is allowed, with a maximum dimension change of 1mm. The unit must remain fully operative and full specification for the main RF parameters.
Electro Static Discharge Test	IEC 1000-4-2.	No performance degradation allowed after the test.
Salt Mist Test	IEC 68-2-11	After the test, visual inspection on the unit.
Atmosphere Test	Flowing mixed gas corrosion. IEC 68-2-60	After the test, visual inspection on the unit and inside.
Marking Test	EN 60 950	After the test, visual inspection on the unit. No degradation is allowed on the marking.

3.2 FTA Compliance

The Integra has received a Full-Type Approval (according to normal MS requirements) in the configuration using the internal SIM interface.

3.2.1 IMEI Number

GSM 900/1800:

TAC: 5 000 64

FAC: 11

Serial Numbers: 000000 to 999999

Integra

GSM 900/1900:
TAC: 500 100
FAC: 11
Serial Number: 000000 to 999999

GSM/GPRS 900/1800:
TAC: 500161
FAC: 11
Serial Numbers: 000000 to 999999

GSM/GPRS 900/1900:
TAC: 500167
FAC: 11
Serial Number: 000000 to 999999

3.2.2 CE Label

The Integra integrated modem is CE compliant which implies that the modem is in conformity with the European Community directives and it bears the CE label

Carrying out tests:
Electro-magnetic field immunity
EN 61000-4-3
ETS 300-342—1

Radiated emission
EN 55022
ETS 300-342

ESD immunity
EN 61000-4-2
ETS 300-342-1

4 Hardware Interfaces

This chapter describes the hardware interfaces:

- interfaces on the 50-pin general purpose connector
- RF interface
- SIM interface

4.1 Interfaces on the 50-pin general purpose connector

4.1.1 The 50-pin connector description

Table 2 : 50-pin connector description

Pin #	Name	I/O	I/O type	Description	Comment
1	GND			GROUND	High current
2	GND			GROUND	High current
3	+5V		Supply		High current
4	+5V		Supply		High current
5	CT109/DCD	O	CMOS/2X	RS232-Data Carrier Detect	
6	GND			GROUND	High current
7	GPIO4	I/O	CMOS/2X	General Purpose I/O	
8	SPK2N	O	Analog	Speaker2 negative output	
9	CT125/RI	O	CMOS/2X	RS232-Ring Indicator	
10	SPK2P	O	Analog	Speaker 2 positive output	
11	Flashing LED	I/O	CMOS/2X	Working mode indication Led	Driven by module
12	SPK1P	O	Analog	Speaker 1 positive output	
13	CT106/CTS	O	1X	RS232 interface Clear To Send	
14	SPK1N	O	Analog	Speaker 1 negative output	
15	ON/~OFF	I		Power ON/OFF control	ON = VCC ⁽³⁾
16	MIC2P	I	Analog	Microphone 2 positive input	
17	AUXV0	I	Analog	Auxiliary ADC input	
18	MIC2N	I	Analog	Microphone 2 negative input	
19	~RST	I		Reset active low	Open Collector
20	MIC1P	I	Analog	Microphone 1 positive input	
21	GND	I		Ground	
22	MIC1N	I	Analog	Microphone 1 negative input	
23	BOOT	I		BOOT	Open Collector
24	GND			GROUND	High current
25	CT103/TX	I		RS232 interface - Transmit	Pull up to VCC ⁽³⁾ with 100K Ω when not used

Pin #	Name	I/O	I/O type	Description	Comment
26	GPIO0	I/O	CMOS/2X	General Purpose I/O	
27	CT107/DSR	O	1X	RS232 interface Data Set Ready	
28	CT104/RX	O	1X	RS232 interface – Receive	
29	CT108-2/DTR	I		RS232 interface Data Terminal Ready	Pull up to VCC ⁽³⁾ with 100KΩ when not used
30	CT105/RTS	I		RS232 interface Request To Send	Pull up to VCC ⁽³⁾ with 100KΩ when not used
31	COL3	I/O	1X	Keypad column	
32	COL4	I/O	1X	Keypad column	
33	COL1	I/O	1X	Keypad column	
34	COL2	I/O	1X	Keypad column	
35	ROW4	I/O	1X	Keypad row	
36	COL0	I/O	1X	Keypad column	
37	ROW2	I/O	1X	Keypad row	
38	ROW3	I/O	1X	Keypad row	
39	ROW0	I/O	1X	Keypad row	
40	ROW1	I/O	1X	Keypad row	
41	GND ⁽¹⁾ NC ⁽²⁾			GROUND ⁽¹⁾ No Connected ⁽²⁾	High current
42	SPI_EN	O	1X	SPI enable	
43	SPI_IO	I/O	1X	I ² C Data or SPI Data	
44	SPI_CLK	O	1X	I ² C Clock or SPI Clock	
45	SIMCLK	O	2X	Clock for SIM Interface	3V mode
46	SIMRST	O	2X	Reset for SIM interface	3V mode
47	SIMVCC	O		SIM card supply	3V mode 6mA max
48	SIMPRES1	I		SIM card detect	Connected to SIM connector pin 8. Pin 4 of SIM connector must be pulled down to GND with 1 KΩ*
49	SIMDATA	I/O	3X	I/O for SIM interface	3V mode
50	GND ⁽¹⁾ , GPO0 ^{(2)**}			See (1) and (2)	High current

⁽¹⁾ for engineering sample

⁽²⁾ for production unit.

⁽³⁾ vcc = application digital power supply either 5V or 2.8V

*see SIM socket diagram [4.3 SIM interface](#)

** GPO0 is a general purpose output for selection of external SIM 3V or 5V

Table 3 : operating conditions

Parameter	I/O type	Min	Max	Condition
$V_{\text{input low}}$	CMOS	-0.5 V	0.8 V	
$V_{\text{input high}}$	CMOS	2.1 V	3.0 V	
$V_{\text{output low}}$	1X		0.2 V	$I_{\text{OL}} = -1 \text{ mA}$
	2X		0.2 V	$I_{\text{OL}} = -2 \text{ mA}$
	3X		0.2 V	$I_{\text{OL}} = -3 \text{ mA}$
$V_{\text{output high}}$	1X	2.6 V		$I_{\text{OH}} = 1 \text{ mA}$
	2X	2.6 V		$I_{\text{OH}} = 2 \text{ mA}$
	3X	2.6 V		$I_{\text{OH}} = 3 \text{ mA}$

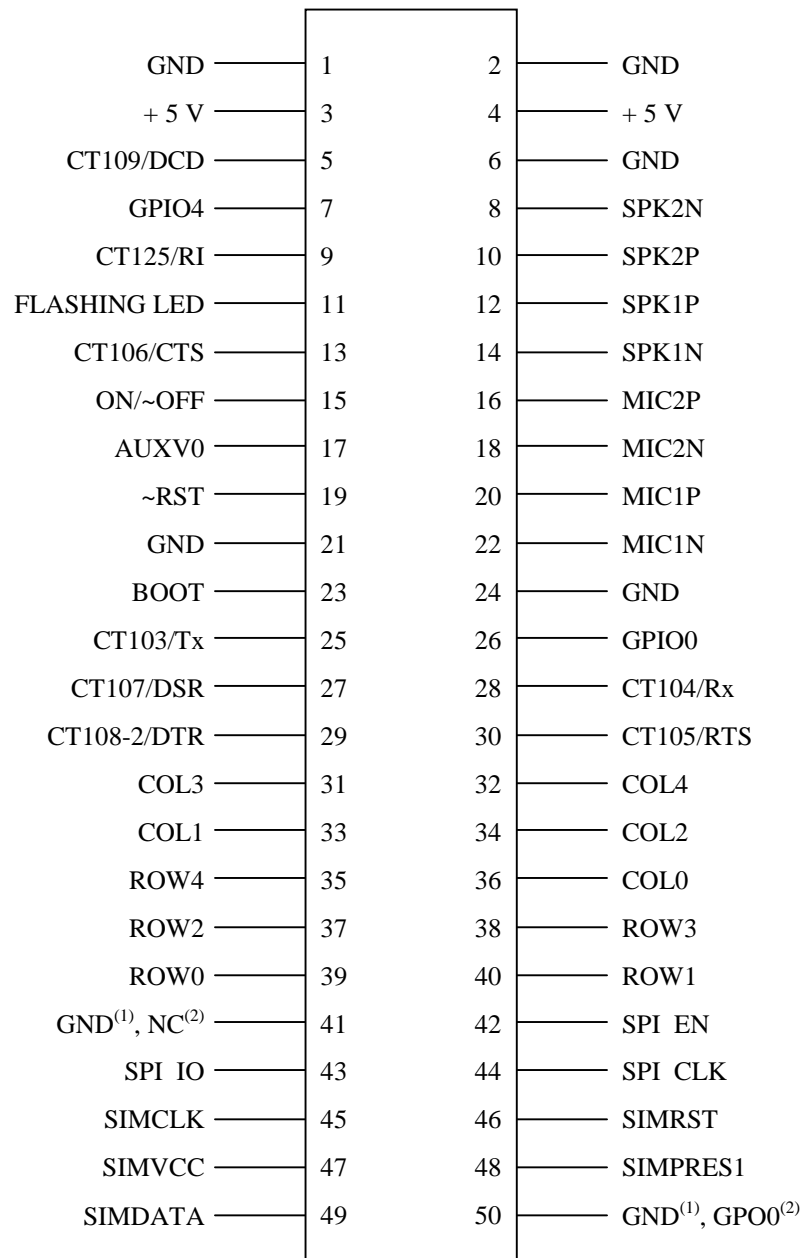

(1) for engineering sample

(2) for production unit

figure 3 : 50-pin connector

Integra

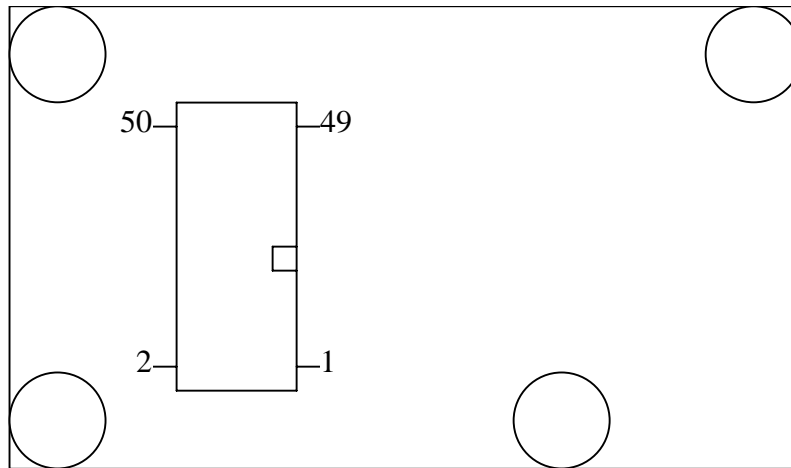

figure 4 : pin numbering/bottom view

4.1.2 Power supply

The main power supply is provided through a double connection. These connections are respectively the pin 3 and 4 for the +5V and the pins 1 and 2 for the ground (GND). The pins 6, 21, 24 and 40 are also ground connection in order to produce a proper ground plane.

A 5V +/-5% - 1A power is strictly required to supply the modem. Otherwise, serious dysfunctions may appear. However, the modem does not have to constantly deliver 1A current at 5V on this power supply.

This power supply is internally regulated to a nominal value VBATT.

Table 4 : power supply pin description

Pin number	Name	Description	Comment
1	GND	Ground	High Current
2	GND	Ground	High Current
3	+5 V	Ground	High Current
4	+5 V	Ground	High Current
6	GND	Ground	High Current
21	GND	Ground	High Current
24	GND	Ground	High Current
41*	GND	Ground	High Current
50*	GND	Ground	High Current

*for engineering sample

Table 5 : Power consumption in EGSM only mode @ 25°C

	Conditions	I _{NOM}	I _{MAX}
+5V	During TX bursts @ 2W	810 mA	1 A
+5V	Average @ 2W	310 mA	370 mA
+5V	Average @ 0.5W	185 mA	200 mA
+5V	Average Idle mode	22 mA	25 mA
+5V	Average Idle with power saving mechanism activated	9.2 mA	10.5 mA

Table 6 : Power consumption in GSM only 1800 and1900 mode @ 25°C

	Conditions	I _{NOM}	I _{MAX}
+5V	During TX bursts @ 1W	635 mA	800 mA
+5V	Average @ 1W	260 mA	280 mA
+5V	Average @ 0.25W	150 mA	170 mA
+5V	Average Idle mode	20 mA	22 mA
+5V	Average Idle with power saving mechanism activated	9.2 mA	10.5 mA

Table 7 : Power consumption in EGSM/GPRS cl2 mode @ 25°C

	Conditions	I _{NOM}	I _{MAX}
+5V	During TX bursts @ 2W	810 mA	1 A
+5V	Average @ 2W	310 mA	370 mA
+5V	Average @ 0.5W	185 mA	200 mA
+5V	Average in GPRS @ 2W	410 mA	490 mA
+5V	Average Idle mode	22 mA	25 mA
+5V	Average Idle with power saving mechanism activated	9.2 mA	10.5 mA

Table 8 : Power consumption GSM/GPRS cl2 1800 or 1900 mode @ 25°C

	Conditions	I _{NOM}	I _{MAX}
+5V	During TX bursts @ 1W	635 mA	800 mA
+5V	Average @ 1W	260 mA	280 mA
+5V	Average @ 0.25W	150 mA	170 mA
+5V	Average in GPRS @ 1W	360 mA	400 mA
+5V	Average Idle mode	20 mA	22 mA
+5V	Average Idle with power saving mechanism activated	9.2 mA	10.5 mA

4.1.3 Serial link

A serial link interface is available complying with V24 protocol signalling but not with V28 (electrical interface) due to a 2.8 Volts interface. TX, RTS and DTR can be either 5V or 3V.

The signals are Tx data (CT103/TX), Rx data (CT104/RX), Request To Send (CT105/RTS), Clear To Send (CT106/CTS), Data Terminal Ready (CT108-2/DTR) and Data Set Ready (CT107/DSR).

The set of RS232 signals can be required for GSM DATA services application. The 2 additional signals are Data Carrier Detect (CT109/DCD) and Ring Indicator (CT125/RI).

Table 7 : Serial Link pin description

Signal	Pin number	I/O	I/O type*	Description
CT103 / TX	25	I	CMOS	Transmit serial data
CT104 / RX	28	O	1X	Receive serial data
CT105 / RTS	30	I	CMOS	Ready To Send
CT106 / CTS	13	O	1X	Clear To Send
CT107 / DSR	27	O	1X	Data Set Ready
CT108-2 / DTR	29	I	CMOS	Data Terminal Ready
CT109 / DCD	5	O	CMOS / 2X	Data Carrier Detect
CT125 / RI	9	O	CMOS / 2X	Ring Indicator
CT102/GND	21,24...**			Ground

*See Table 3 "operating conditions" in subdivision 4.1.1 [The 50-pin connector description](#)

** Any of the available GND pins can be used

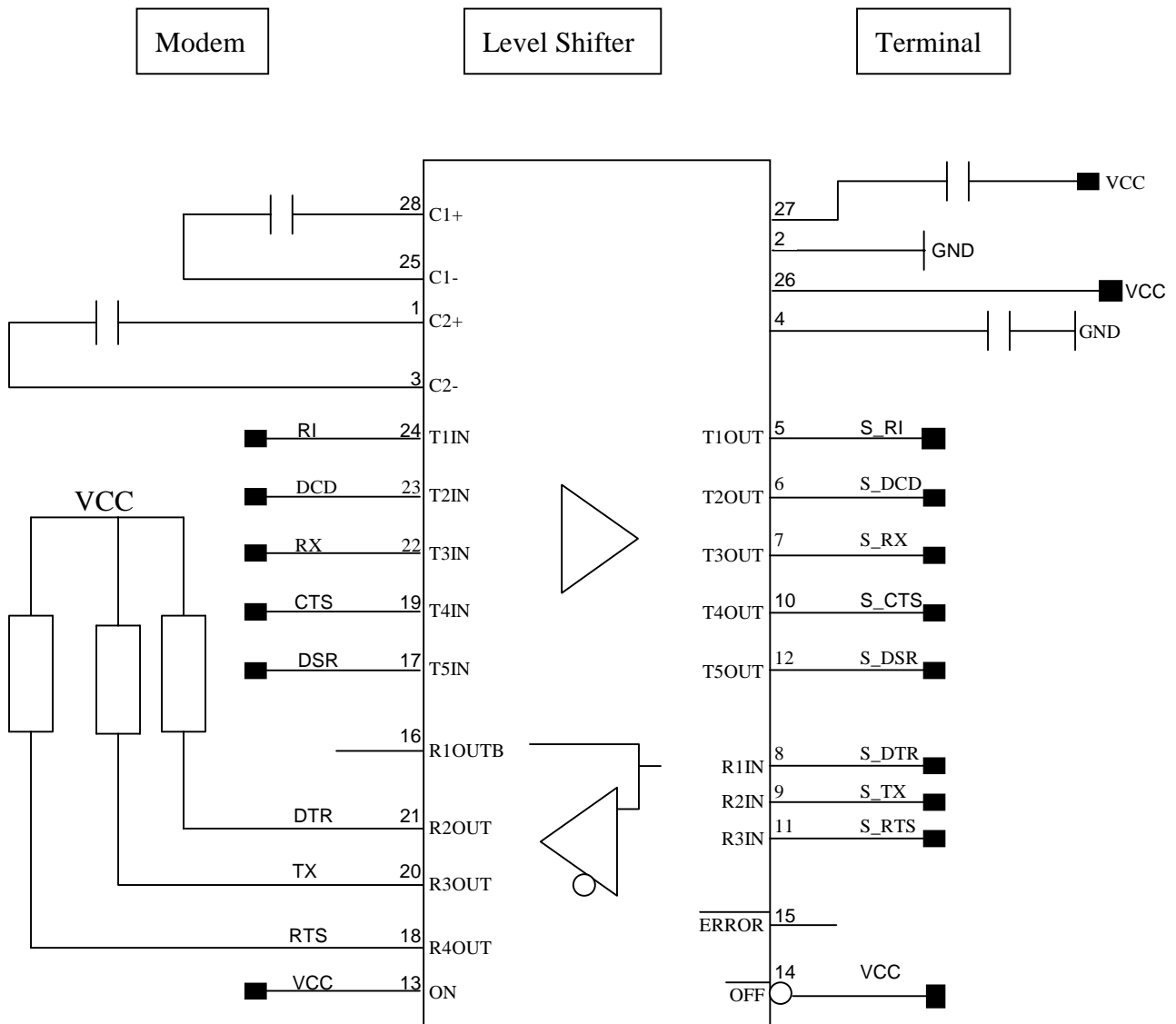

MAX 3238

figure 5* : level shifter application diagram for serial link

* This application note is valid for VCC ≥ 3.0Volt (see MAX3238 specifications). Auto shut down mode is not used in this example.

4.1.4 ON / ~OFF

This input is used to switch ON or OFF the Integra modem. A high level signal has to be provided on the ON/~OFF pin to switch on the modem. The level of the voltage of this signal has to be maintained to VCC during a minimum time of 1 second. When powered off, the shutdown current is roughly 60 µA.

Table 8 : ON / OFF pin description

Signal	Pin number	I/O	I/O type*	Description
ON/~OFF	15	I	CMOS	Module Power ON/OFF

*See Table 3 "operating conditions" in subdivision 4.1.1 [The 50-pin connector description](#)

4.1.4.1 Power OFF procedure

In order to power OFF the Integra, switch it OFF both via software (AT+CPOF, See AT commands user's guide for more details) and via hardware line. See the diagram below.

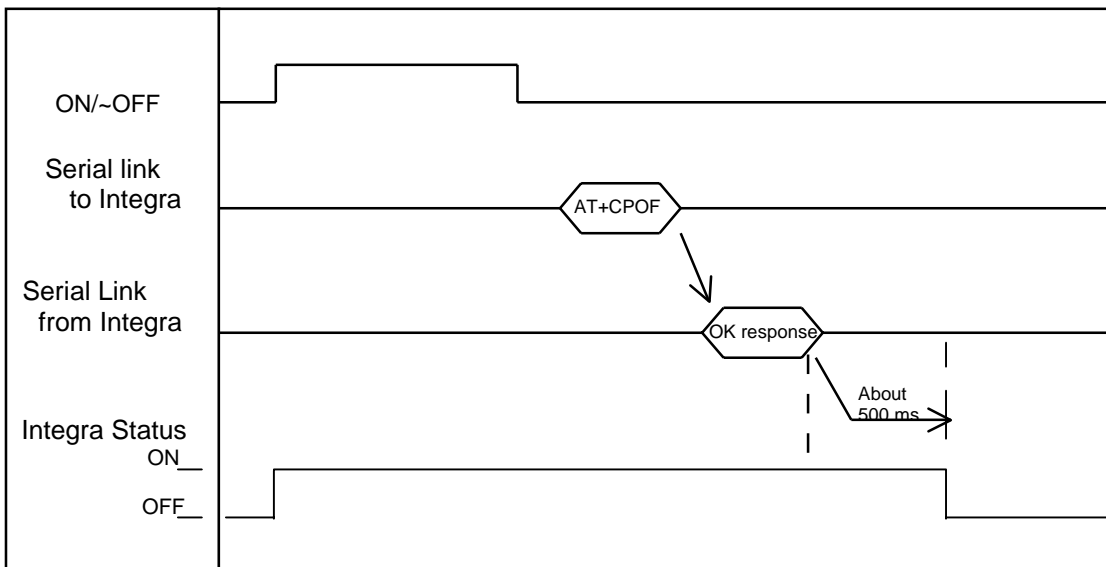

figure 6 : power OFF procedure 1

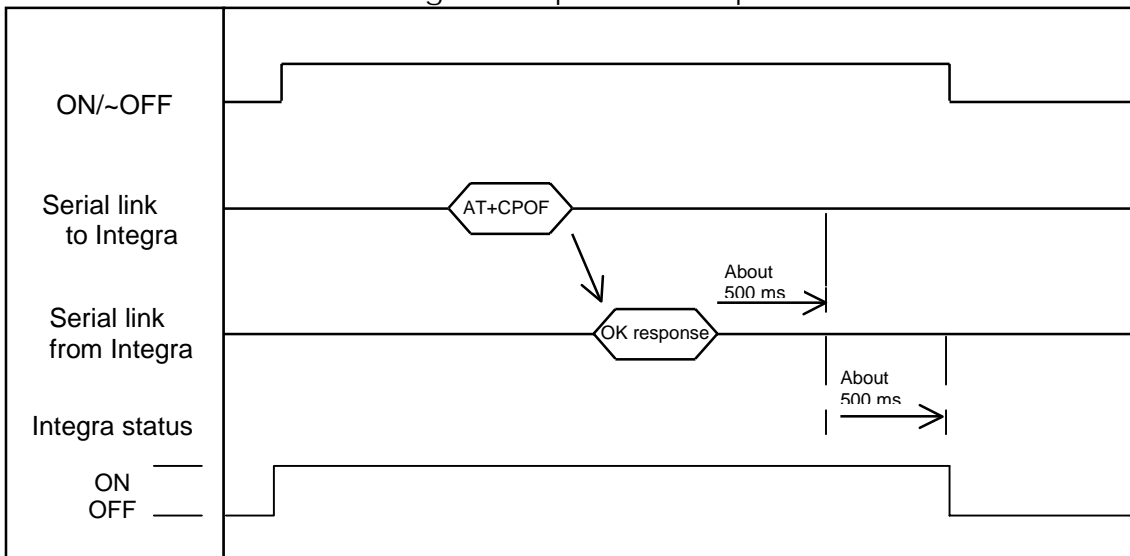

figure 7 : power OFF procedure 2

Integra

4.1.5 BOOT

This input is used to switch the Integra into download mode (backup procedure). The internal boot procedure is started when this pin is low during the power ON of the module. In normal mode, this pin has to be left open. If used, this input has to be driven by an open collector or an open drain. See below an example of application diagram. See also the software upgrade procedure in General Guidelines chapter 8

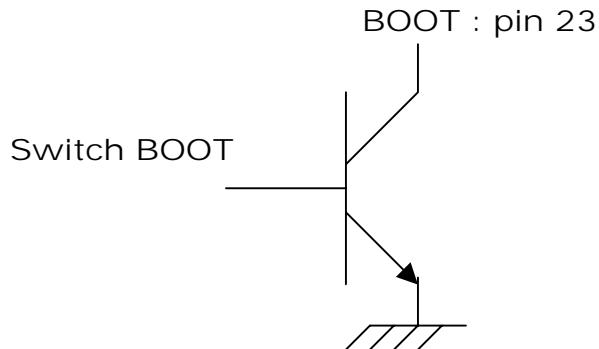

figure 8 : boot procedure

If Switch Boot = 1, Boot pin 23 = 0, to download mode

If Switch Boot = 0, Boot pin 23 = 1, to normal mode

Table 9 : BOOT pin description

Signal	Pin number	I/O	I/O type*	Description
BOOT	23	I	CMOS	SW downloading

*See Table 3 "operating conditions" in subdivision 4.1.1 [The 50-pin connector description](#)

Integra

4.1.6 Reset signal (~RST)

This signal is used to force a reset of the Integra. It has to be used by providing low level during approximately 2ms. This signal has to be considered as an emergency reset only. A reset procedure is already driven by an internal hardware during the power-up sequence.

This signal can also be used to provide a reset to an external device. If no external reset is necessary this input can be left open. If used (emergency reset), it has to be driven by an open collector or an open drain. See below an example of application diagram.

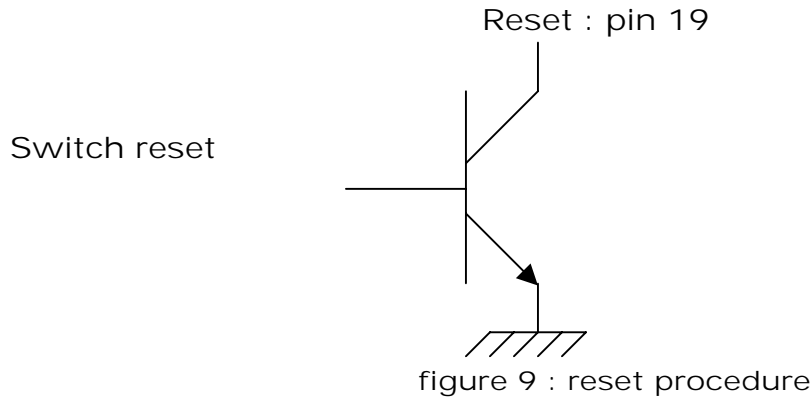

If switch Reset = 1, Reset pin 19 = 0
 If switch Reset = 0, Reset pin 19 = 1

Table 10 : reset signal pin description

Signal	Pin number	I/O	I/O type*	Description
~RST	19	I/O		Module Reset

*See Table 3 "operating conditions" in subdivision 4.1.1 [The 50-pin connector description](#)

Table 11 : reset signal electrical characteristics

Parameter	Min	Max	Unit
Input Impedance (R)	4.7		kΩ
Input Impedance (C)		10	NF

Table 12 : reset signal operating conditions

Parameter	Min	Max	Condition
*V _{T-}	1.1V	1.2 V	
*V _{T+}	1.7V	1.9 V	
V _{OL}		0.4 V	I _{OL} = -50 μA
V _{OH}	2.0 V		I _{OH} = 50 μA

V_{T-}, V_{T+}: Hysterisis Level

4.1.7 Flashing LED

The flashing LED signal is used to indicate the working mode of the Integra.

Table 13 : the flashing LED pin description

Signal	Pin number	I/O	I/O type*	Description
Flashing LED	11	I/O	CMOS/2X	Working mode indication LED

*See Table 3 "operating conditions" in subdivision 4.1.1 [The 50-pin connector description](#)

Table 14 : LED and Integra status

LED status	Integra status	
OFF	Download mode or switched OFF	
ON	Permanent	Switched ON, not registered on the network
	Slow flash	Switched ON, registered on the network
	Quick flash	Switched ON, registered on the network, communication in progress

Integra

4.1.8 General Purpose Input/Output

The Integra provides 2 General Purpose I/O. They are used to control any external device.

Table 15 : General Purpose pin description

Signal	Pin number	I/O	I/O type*	Description	Default value
GPIO0	26	I/O	CMOS / 2X	General Purpose I/O	0
GPIO4	7	I/O	CMOS / 2X	General Purpose I/O	0

*See Table 3 "operating conditions" in subdivision 4.1.1 [The 50-pin connector description](#)

All digital I/O comply with 3Volts CMOS.

You can access (write or read) the GPIO value via AT+WIOW and AT+WIOR. See AT commands user's guide for more details.

4.1.9 Analog to Digital Converter

Analog to Digital converter (ADC) input is provided by the Integra. This converter is a 10 bits one, ranging from 0 to 2.5V. You can see the measurements via AT+ADC. See AT commands user's guide for more details.

Table 16 : A/D converter pin description

Signal	Pin number	I/O	I/O type*	Description
AUXV0	17	I	Analog	A/D converter

*See Table 3 "operating conditions" in subdivision 4.1.1 [The 50-pin connector description description](#)

Table 17 : A/D converter electrical characteristics

Parameter	Min	Max	Unit
Resolution	10		bits
Sampling rate	90.3		Ksps
Input signal range	0	2.5V	V
ADC Reference Accuracy	0.5		%
Integral Accuracy	+/- 1		LSB
Differential Accuracy	+/- 1		LSB
Input Impedance (R)	10		MΩ
Input Impedance (C)		50	pF

Integra

4.1.10 Audio Interface

Two different microphone inputs and two different speaker outputs are supported. The connection can be either differential or single-ended but using a differential connection in order to reject common mode noise and TDMA noise is recommended.

4.1.10.1 Microphone 2 Inputs

The MIC2 inputs are differential ones. They already include the convenient biasing for an electret microphone (0,5 mA and 2 Volts). This electret microphone can be directly connected on these inputs. The impedance of the microphone 2 has to be around 2kΩ. These inputs are the standard ones for a handset design while MIC1 inputs can be connected to an external headset or a handsfree kit.

The gain of MIC2 inputs is internally adjusted. The gain can be tuned from 30dB to 51dB. The connection to the microphone is direct. The gain can be tuned using the AT+VGR command.

See chapter Connector suppliers and peripheral devices.

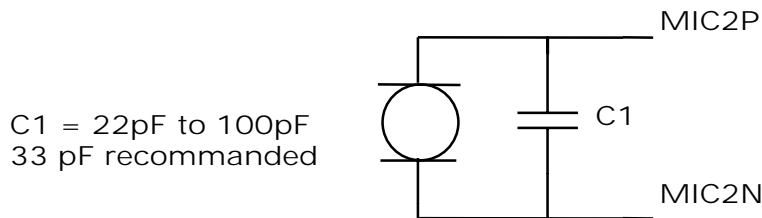

figure 10 : microphone 2 input

C1 has to be the nearest as possible to the microphone. Microphone manufacturers provide this capacitor directly soldered on the microphone.

Table 18 : microphone 2 input pin description

Signal	Pin #	I/O	I/O type*	Description
MIC2P	16	I	Analog	Microphone 2 positive input
MIC2N	18	I	Analog	Microphone 2 negative input

*See Table 3 "operating conditions" in subdivision 4.1.1 [The 50-pin connector description](#)

Integra

4.1.10.2 Microphone 1 Inputs

The MIC1 inputs are differential and do not include internal bias. To use these inputs with an electret microphone, bias has to be generated outside the INTEGRA modem according to the characteristic of this electret microphone. These inputs are the standard ones used for an external headset or a handsfree kit. When using a single-ended connection, be sure to have a very good ground plane, a very good filtering as well as shielding in order to avoid any disturbance on the audio path. The gain of MIC1 inputs is internally adjusted. The gain can be tuned from 30dB to 51dB.

The gain can be tuned using the AT+VGR command.

Differential connection

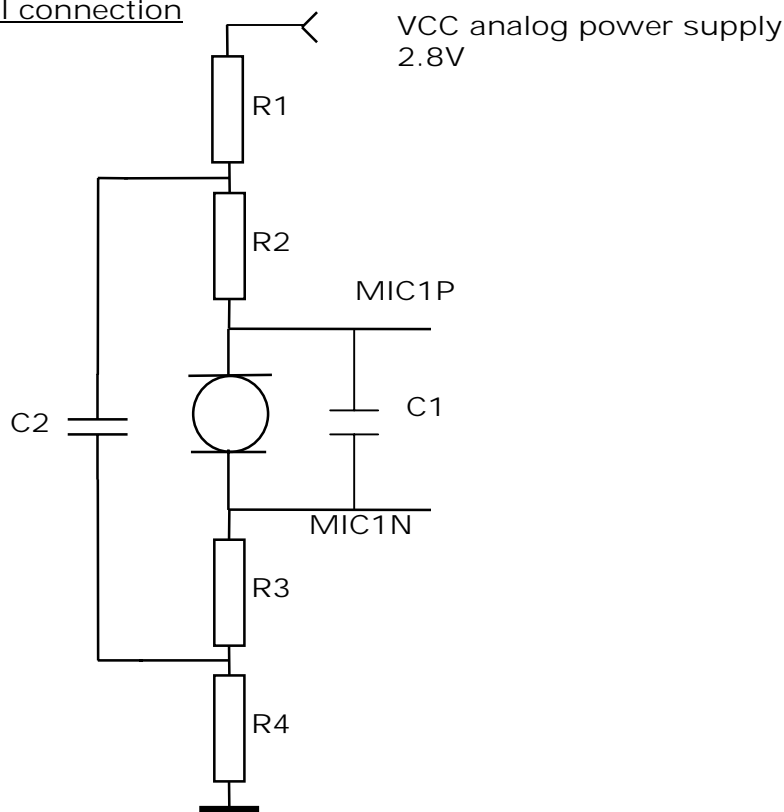

figure 11 : microphone 1 input

R1 = R4 = from 100 to 330 Ω

R2 = R3 = usually between 1K Ω and 3.3K Ω as per the microphone characteristics

C1 = 22pF to 100pF

C2 = 47 μ F

R1 and R4 are used as a voltage supply filter with C2.

C1 has to be the nearest possible to the microphone. Microphone manufacturers provide this capacitor directly soldered on the microphone.

Table 19 : microphone 1 input pin description

Signal	Pin #	I/O	I/O type*	Description
MIC1P	20	I	Analog	Microphone 1 positive input
MIC1N	22	I	Analog	Microphone 1 negative input

*See Table 3 "operating conditions" in subdivision 4.1.1 [The 50-pin connector description](#)

4.1.10.3 Speaker 2 Outputs

Speaker outputs SPK2 are push-pull amplifiers and can be loaded down to 50 Ohms and up to 1nF. These outputs are differential and the output power can be adjusted by step of 2dB. The output can be directly connected to a speaker. When using a single-ended connection, be sure to have a very good ground plane, a very good filtering as well as shielding in order to avoid any disturbance on the audio path.

Differential Connection

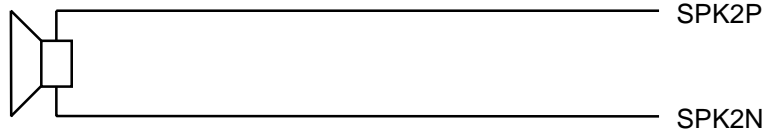

Single-ended Connection

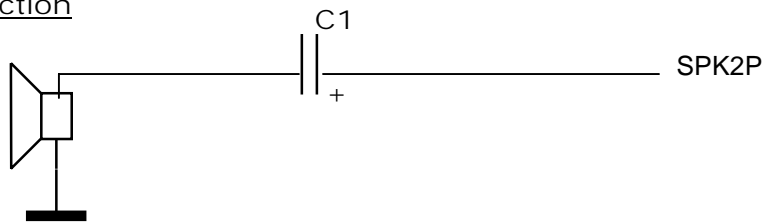

figure 12 : speaker 2 output

C1 = from 100nF to 47µF as per the speaker characteristics and the output power.

Using a single-ended connection also includes losing half of the output power compared to a differential connection.

Table 20 : speaker 2 output pin description

Signal	Pin #	I/O	I/O type*	Description
SPK2P	10	O	Analog	Speaker 2 positive output
SPK2N	8	O	Analog	Speaker 2 negative output

*See Table 3 "operating conditions" in subdivision 4.1.1 [The 50-pin connector description](#)

Integra

4.1.10.4 Speaker 1 Outputs

Speaker outputs SPK1 are push-pull amplifiers and can be loaded down to 50 Ohms and up to 1nF. These outputs are differential and the output power can be adjusted by step of 2dB. The output can be directly connected to a speaker. When using a single-ended connection, be sure to have a very good ground plane, a very good filtering as well as a shielding in order to avoid any disturbance on the audio path.

Differential Connection

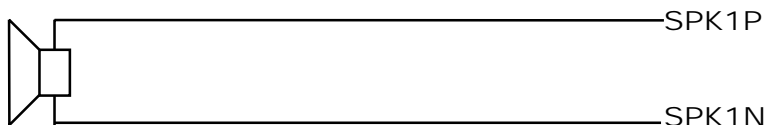

Single-ended Connection

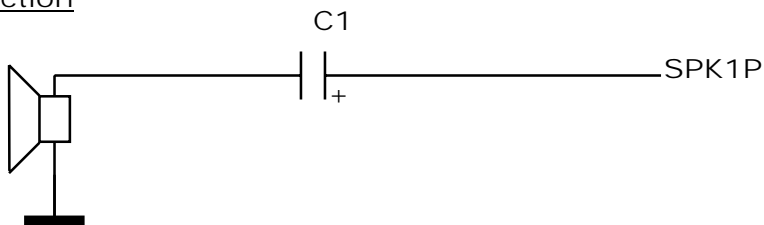

figure 13 : speaker 1 output

C1 = from 100nF to 47µF as per the speaker characteristics.
Using a single-ended connection also includes losing half of the output power compared to a differential connection.

Table 21 : speaker 1 output pin description

Signal	Pin #	I/O	I/O type*	Description
SPK1P	12	O	Analog	Speaker 1 positive output
SPK1N	14	O	Analog	Speaker 1 negative output

*See Table 3 "operating conditions" in subdivision 4.1.1 [The 50-pin connector description](#)

Integra

4.1.11 SIM interface

The external SIM interface is available through the 50-pin connector in order to use a stand-alone SIM card holder. **This interface is 3V only on the engineering samples. 5V SIMs can be driven with production unit using an external level shifter.**

SIM line must not exceed 15 cm. see also "General guidelines" chapter 8

5 signals are available:

SIMVCC: SIM power supply.

SIMRST: reset.

SIMCLK: clock.

SIMDATA: I/O port.

SIMPRES1 SIM card detect. This signal is connected to the external SIM connector on pin 8. Pin 4 of SIM connector must be pulled down to GND with 1 K Ω .

This interface is fully compliant with GSM 11.11 recommendations concerning the SIM functionality.

Transient Voltage Suppressor diodes are internally added on the signals connected to the SIM socket in order to prevent any Electro-Static Discharge. TVS diodes with low capacitance (less than 10pF) are connected on SIMCLK and SIMDATA to avoid any disturbance of the rising and falling edge.

Table 22 : SIM interface pin description

Signal	Pin number	I/O	I/O type*	Description
SIMCLK	45	O	2X	SIM Clock
SIMRST	46	O	2X	SIM Reset
SIMDATA	49	I/O	CMOS / 3X	SIM Data
SIMVCC	47	O		SIM Power Supply
SIMPRES1	48	I	CMOS	SIM Card Detect
GPO0**	50	O	2X	SIM 3V or 5V

*See Table 3 "operating conditions" in subdivision 4.1.1 [The 50-pin connector description](#)

** for production units

See [application schematics in annex](#) for 3V/5V SIM management

Table 23 : SIM interface electrical characteristics

Parameter	Conditions	Min	Typ	Max	Unit
SIMDATA V_{IH}	$I_{IH} = \pm 20\mu A$	$0.7 \times SIMVCC$			V
SIMDATA V_{IL}	$I_{IL} = 1mA$			$0.3 \times SIMVCC$	V
SIMRST, SIMDATA SIMCLK V_{OH}	Source current = $20\mu A$	$SIMVCC - 0.1V$			V
SIMRST, SIMDATA SIMCLK V_{OL}	Sink current = $-200\mu A$			0.1	V
SIMVCC Output Voltage	$I_{SIMVCC} \leq 6mA$	2.70	2.80	2.85	V
SIMCLK Rise/Fall Time	Loaded with 30pF			50	ns
SIMRST, SIMDATA Rise/Fall Time	Loaded with 30pF			1	μs
SIMCLK Frequency	Loaded with 30pF			3.25	MHz

Table 24 : SIM socket pin description

Signal	Pin number	Description
VCC	1	SIMVCC
RST	2	SIMRST
CLK	3	SIMCLK
CC4	4	R10 to GROUND
GND	5	GROUND
VPP	6	Not connected
I/O	7	SIMDATA
CC8	8	SIMPRES1

Integra

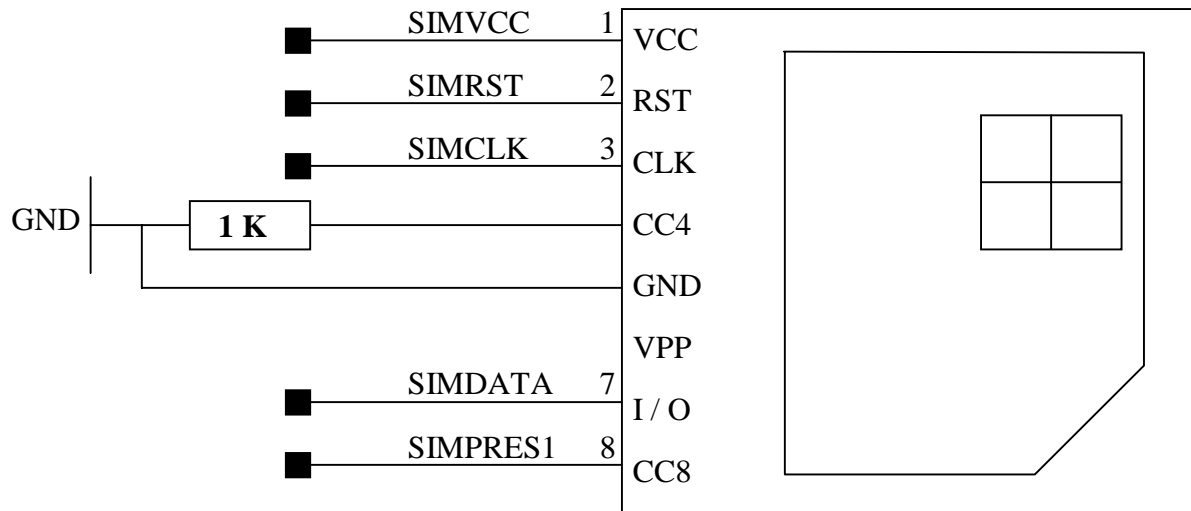

Figure 14: SIM socket

4.1.12 SPI bus

The SPI bus includes a CLK signal, an I/O signal and an EN signal complying with SPI bus standard. The maximum speed transfer is 3.25Mb/s.

Table 25 : SPI Bus pin description

Signal	Pin number	I/O	I/O type*	Description
SPI_CLK	44	O	1X	SPI Serial Clock
SPI_IO	43	I/O	CMOS / 1X	SPI Data
SPI_EN	42	O	1X	SPI Enable

*See Table 3 "operating conditions" in subdivision 4.1.1 [The 50-pin connector description](#)

4.1.13 Keypad interface

This interface provides 10 connections : 5 rows (R0 to R4) and 5 columns (C0 to C4).

The scanning is a digital one, and the debouncing is done in the integrated modem. No discrete components like R,C (Resistor, Capacitor) are needed.

It is possible to scan the column and rows using the: AT+ CMER. command. See AT command user's guide for more details.

Table 26 : keypad interface pin description

Signal	Pin number	I/O	I/O type*	Description
ROW0	39	I/O	CMOS / 1X	Row scan
ROW1	40	I/O	CMOS / 1X	Row scan
ROW2	37	I/O	CMOS / 1X	Row scan
ROW3	38	I/O	CMOS / 1X	Row scan
ROW4	35	I/O	CMOS / 1X	Row scan
COL0	36	I/O	CMOS / 1X	Column scan
COL1	33	I/O	CMOS / 1X	Column scan
COL2	34	I/O	CMOS / 1X	Column scan
COL3	31	I/O	CMOS / 1X	Column scan
COL4	32	I/O	CMOS / 1X	Column scan

*See Table 3 "operating conditions" in subdivision 4.1.1 [The 50-pin connector description](#)

Integra

4.2 RF Interface

The impedance is 50 Ohms nominal.

4.2.1 RF connector

The RF connector is MMCX (Miniature Micro Connector) standard type. An antenna can be directly connected through the mating connector or using a small adaptor. See also paragraph on GSM antenna.

4.2.2 RF performances

RF performances are compliant with the ETSI recommendation 05.05 and 11.10. The main parameters are :

- Receiver:
- EGSM Sensitivity : < -104 dBm
- GSM 1800/GSM 1900 Sensitivity : < -102 dBm
- Selectivity @ 200 kHz : > +9 dBc
- Selectivity @ 400 kHz : > +41 dBc
- Dynamic range : 62 dB
- Intermodulation : > -43 dBm
- Co-channel rejection : + 9 dBc

Transmitter :

- Maximum output power (EGSM) : 33 dBm +/- 2 dB
- Maximum output power (DCS/PCS) : 30 dBm +/- 2 dB
- Minimum output power (EGSM): 5 dBm +/- 5 dB
- Minimum output power (DCS/PCS): 0 dBm +/- 5 dB
- H2 level : < -30 dBm
- H3 level : < -30 dBm
- Noise in 925 - 935 MHz : < -67 dBm
- Noise in 935 - 960 MHz : < -79 dBm
- Noise in 1805 - 1880 MHz : < -71 dBm
- Phase error at peak power : < 5 ° RMS
- Frequency error : +/- 0.1 ppm max

4.3 SIM interface

The internal SIM interface of the Integra supports **3V SIMs only**.

The part number reference of the SIM card holder supplier is MOLEX 91228-0002

The part number reference of the SIM receptacle supplier is MOLEX 91236-0002

See also subdivision [The SIM card holder](#).

5 Connector Supplier and Peripheral devices

5.1 Where to find the SMD connectors

The Integra matting interface connector is made by SAMTEC France (<http://www.samtec.com/>).

Many SAMTEC products are available via SAMTEC dealers throughout the world. The connectors [data sheets are available in annex](#) of this document.

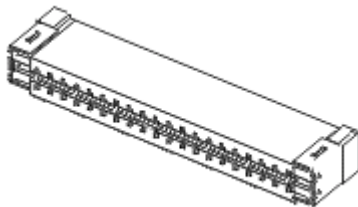

Figure 15: high and low profile CLP connectors



Part number : FFSD-20-S-10-01-N

Figure 16: flexible flat cable



Part number : FLE 125 01LDVA

Figure 17: flex cable connector

Integra

5.1.1 GSM Antenna

The integrated modem antenna connector is a MMCX connector. The MMCX connector incorporates a 'Snap On' latching action in order to make the connection easier with an excellent RF performance. An additional advantage is its small physical size which is 50% of the standard MCX connector.

This type of connector is suitable for the standard ranges of flexible and semi-rigid cables. The characteristic impedance of the MMCX coaxial connector is 50 ohm.

The antenna manufacturer must guarantee that the antenna will be working according to the following radio characteristics:

Table 27 : radio characteristics

	EGSM 900	GSM 1800	GSM 1900
Frequency RX	925 to 960 MHz	1805 to 1880 MHz	1930 to 1990 MHz
Frequency TX	880 to 915 MHz	1710 to 1785 MHz	1850 to 1910 MHz
RF power stand	2W at 12.5 % duty cycle	1W at 12.5 % duty cycle	1W at 12.5 % duty cycle
Impedance	50 Ω		
VSWR	< 2		
Typical radiated gain	0 dBi on azimuth plane		

The Integra requires an MMCX (Miniature Micro Connector) plug to connect an antenna



Figure 18: MMCX connector example (right angle)

An antenna with matting connector can be ordered, for example, from :

IMS Connectors Systems GMBH

Obere Hauptstrasse 30

D-79843 Löffingen

Germany

Tel : +49 76 54 90 10

Fax : +49 76 54 90 11 99

<http://www.imscs.com/>

or using a small MMCX / SMA adaptor can be ordered, for example, from :

Amphenol Socapex

<http://www.amphenol.com/>

Order N° : 908-31100

Integra

5.1.2 The SIM card holder

The SIM card holder used in the integrated modem is a MOLEX connector.

Part number connector: 99228-0002

Part number holder : 91236-0002

For more information about this connector :

<http://www.molex.com/>

It is possible to use a stand-alone SIM card holder through the 50-pin connector (the length of the SIM line must not exceed 15 cm).

6 Climatic and mechanical environment

Table 28 : climatic and mechanical environment

WM2C-G900/G1800		ENVIRONNEMENTAL CLASSES					
TYPE OF TEST	STANDARDS	STORAGE Class 1.2		TRANSPORTATION Class 2.3		OPERATING (PORT USE) Class 7.3	
Cold	IEC 68-2.1 Ab test	-25° C	72 h	-40° C	72 h	-20° C (GSM) -10° C (DCS)	16 h 16 h
Dry heat	IEC 68-2.2 Bb test	+70° C	72 h	+70° C	72 h	+55° C	16 h
Change of temperature	IEC 68-2.14 Na/Nb test			-40° / +30° C	5 cycles t1 = 3 h	-20° / +30° C (GSM) -10° / +30° C (DCS)	3 cycles 3 cycles t1 = 3 h
Damp heat cyclic	IEC 68-2.30 Db test	+30° C 90% - 100% RH variant 1	2 cycles	+40° C 90% - 100% RH variant 1	2 cycles	+40° C 90% - 100% RH variant 1	2 cycles
Damp heat	IEC 68-2.56 Cb test	+30° C	4 days	+40° C	4 days	+40° C	4 days
Sinusoidal vibration	IEC 68-2.6 Fc test	5 - 62 Hz : 5 mm / s 62 - 200Hz : 2 m / s ² 3 x 5 sweep cycles					
Random vibration wide band	IEC 68-3.36 Fdb test			5 - 20 Hz : 0.96 m ² / s ³ 20 - 500Hz : - 3 dB / oct 3 x 10 min		10 - 12 Hz : 0.96 m ² / s ³ 12 - 150Hz : - 3 dB / oct 3 x 30 min	

Integra

7 Demonstration board

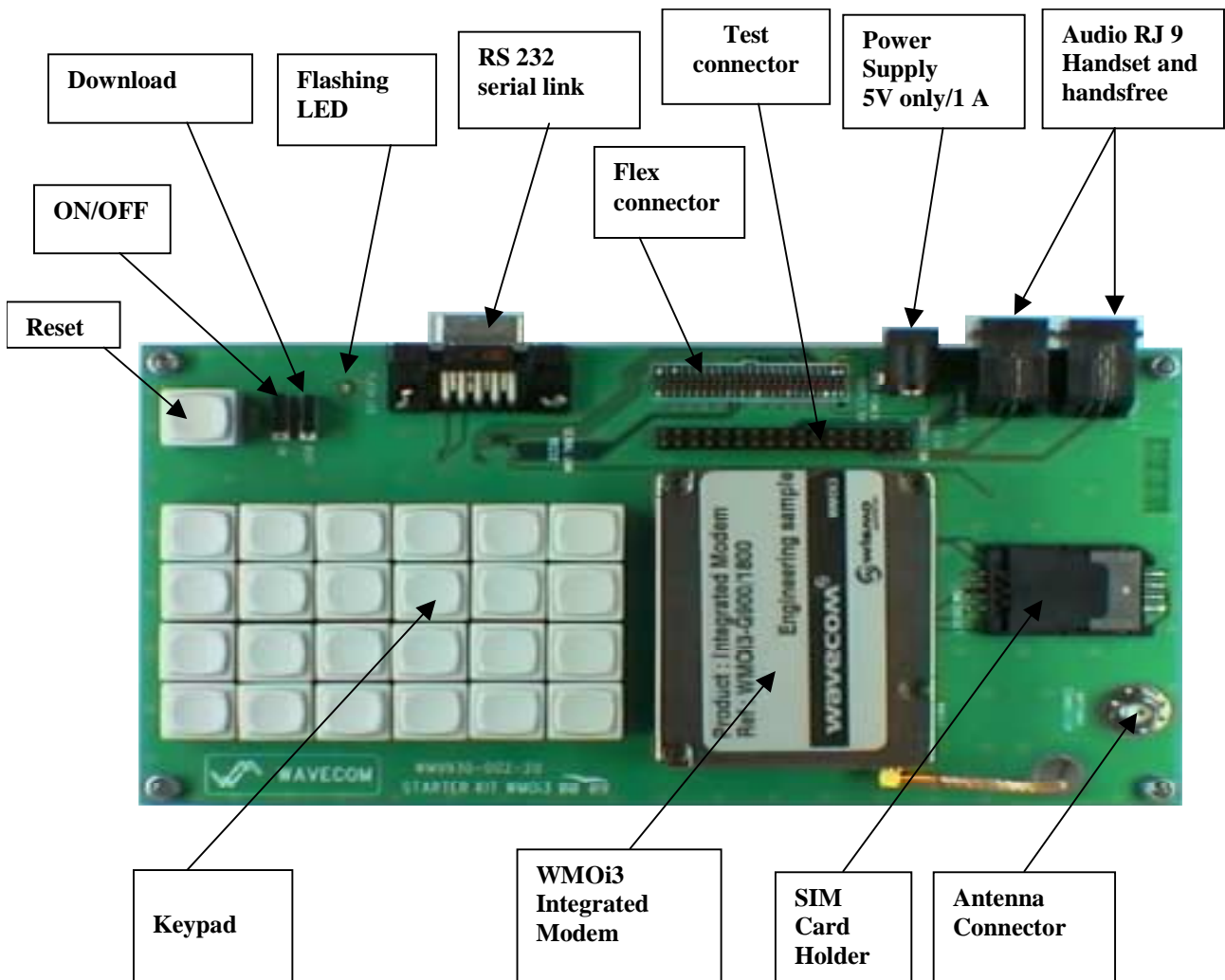

Figure 19: Integra demoboard description

The Wavecom demonstration board ("demoboard") is manufactured by Wavecom. It can be ordered from Wavecom or directly from your distributor.

8 General guidelines for the use of the Integra

8.1 Key information

8.1.1 Hardware and RF

- Ground plane: Wavecom recommends to have a common ground plane for analog, digital and RF grounds.
- Length of the SIM interface lines (15 cm maximum)
- Bias of the Microphone inputs must be properly adjusted when using audio connectors (mic + speaker) 1.
- EMC protection on audio input/output (filters against 900 MHz)
- ESD protection on serial link, ...
- Possible spurious emission radiated by the application to the RF receiver in the receiver band

8.1.2 The Antenna

The antenna sub-system and integration in the application is a major issue. It is a major issue in the choice of the antenna cable (type, length, performances, thermal resistance, etc.)

These elements could affect GSM performances such as sensitivity and emitted power.

The antenna should be isolated as much as possible from the digital circuitry including the interface signals.

It is recommended to shield the terminal. On terminals including the antenna, a poor shielding could dramatically affect the sensitivity of the terminal. Subsequently, the power emitted through the antenna could affect the application.

8.1.3 Firmware upgrade

The Integra firmware is stored in flash memory and it can easily be upgraded.

Two upgrade procedures are available:

- one (nominal) procedure based on the Xmodem protocol (AT+WDWL command)
- one emergency mode (backup procedure) based on a Wavecom specific downloader

8.1.3.1 Nominal upgrade procedure

The firmware file can be downloaded into the modem using the Xmodem protocol. To enter this mode, the AT+WDWL command (see description in the AT command manual) has to be sent to the Integra.

The necessary serial signals to proceed with the Xmodem downloading are:

Rx, Tx, RTS, CTS, GND.

Integra

8.1.3.2 backup procedure

In case the nominal upgrade mode is not possible (due to critical corruption on the flash memory), a backup procedure is also available. It requires a WAVECOM specific software to download the firmware file into the modem.

This tool has to run on a PC connected to the serial bus of the modem. As this procedure is very specific and needs Wavecom tools, this process has to be executed by your distributor.

The necessary signals to proceed with the downloading are: Rx, Tx, RTS, CTS, GND.

Prior to running the WAVECOM downloader, the modem has to be set in download mode.

For this, the BOOT signal has to be set to low while powering ON (or resetting) the modem.

The application must support serial speed changes, up to 115,200 bps and hardware flow control.

8.1.4 Getting started

8.1.4.1 Minimum hardware interface to get started

As a minimum, it is necessary to connect the following signals to properly operate the Integra :

Table 29 : minimum signals to operate the Integra

Pin number	Name	Description
1	GND	GROUND
2	GND	GROUND
3	+5V	Power supply
4	+5V	Power supply
6	GND	GROUND
13	CT106/CTS	Clear To Send
15	ON/OFF	Power On/OFF*
21	GND	GROUND
24	GND	GROUND
25	CT103/TX	Transmit
28	CT104/RX	Receive
30	CT105/RTS	Request To Send

* connected to +5V for example

The serial link signals must be used through the implementation of the serial link level shifter. See [figure 5 : level shifter application diagram for serial link](#)

Integra

8.1.4.2 Terminal emulator setup

Here below is an example based on the Windows™ Hyperterminal application (terminal emulator program).

Setup:

START - PROGRAMS - ACCESSORIES - HYPERTERMINAL , then

Start the software HYPERTRM

Give the name of your choice, click on the icon of your choice, then click "OK", then

choose:

Connect using : direct to COM1

Properties :

choose 9600 bps - 8 bits data - no parity - 1 stop bit - hardware flow control

Click "OK"

Once Hyperterminal is open and configured, it can be used to send AT commands to the Integra.

Please see the "Informative Example" annex in the AT command user's guide to test your Integra.

9 Reference documents

Table 31 : GSM ETSI recommendations for Phase I and Phase II.

Specification Reference	Title
GSM ph2 Radio	ETSI GSM 05.05 and GT 01 v4.2.1
DCS ph2 Radio	ETSI GSM05.05 and GT01 v4.2.1
GSM ph2 Link-Management	ETSI GSM 03.06, 04.08, 05.05, 05.08, 05.10, 07.01 and GT 01 v4.2.1
GSM ph2 Link-Management	ETSI GSM 03.06, 04.08, 05.05, 05.08, 05.10, 07.01 and GT 01 v4.2.1
GSM ph2 Layer 2	ETSI GSM 04.06 and GT 01 v4.2.1
GSM ph2 Layer 3	ETSI GSM 04.08 and GT 01 v4.2.1
DCS ph2 Layer 3	ETSI GSM 04.08 and GT 01 v4.2.1
GSM/DCS Multiband	ETSI GSM 02.07, 03.22, 04.08, 04.13, 05.05, 05.08 and GT 01 v4.2.1
GSM ph2 SIM	ETSI GSM 11.11 and GT 01 v4.2.1
GSM ph2 Teleservices	ETSI GSM 03.50 and GT 01 v4.2.1
GSM ph2 Miscellaneous	ETSI GSM 02.07, 03.40, 03.41, 04.08, 04.10, 04.11, 06.10, 06.11, 06.12, 06.31, 06.32, 07.01, 09.07 and GT 01 v4.2.1
DCS ph2 Miscellaneous	ETSI GSM 02.07, 03.40, 03.41, 04.08, 04.10, 04.11, 06.10, 06.11, 06.12, 06.31, 06.32, 07.01, 09.07 and GT 01 v4.2.1

You can find the documents on

ETSI Contacts:**ETSI Secretariat**

F-06921 Sophia Antipolis cedex, France

e-mail: secretariat@etsi.fr<http://www.etsi.org>

10 Acronyms and Abbreviations

ADC : Analog Digital Converter
ASIC : Application Specific Integrated Circuit
BCCH : Broadcast Control Channel
CE : Communauté Européenne
CLK : Clock
CTS : Clear To send
dB : decibel
DCD : Data Carrier Detect
DCE : Data Circuit Terminating Equipment
DSR : Data Set Ready
DTE : Data Terminal Equipment
DTR : Data Terminated Ready
EFR : Enhanced Full Rate
E-GSM : Extended- GSM
EMC : Electromagnetic Conformity
EN : Enable
ETSI :
FAC : Final Assembly Code
FR : Full-Rate
FTA : Full Type Approval
GND : Ground
GPIO : General Purpose Input Output
GPRS : General Packet Radio Service
GSM : Global System for Mobile Communication
HR : Half-Rate
IMEI : International Mobile Equipment Identity
MO : Mobile Originated
MT : Mobile Terminated
OEM : Original Equipment Manufacturer
PDA : Personal Digital Assistant
PCB : Printed Circuit Board
PRES : Presence
RI : Ring Indicator
RTS : Request To Send
SIM : Subscriber Identity Module
SMD : Surface Mounted Design
SMS : Short Message Service
TAC : Type Approval Code
TDMA : Time Code Multiple Access
TE : Terminal Equipment
VSWR : Voltage Standing Wave Ratio
WAP : Wireless application Protocol

11 Index

- 2
2X, 19, 20, 22, 23, 27, 34, 41
- A**
- Advice of Charge, 9
analog, 12, 52
Analog, 19, 20, 34, 35, 36, 38, 39, 40, 66
antenna, 9, 13, 14, 15, 46, 48, 49, 52
antenna cable, 52
asynchronous, 9
AT commands, 8, 9, 63
AT+ CMER, 44
AT+CPOF, 29
autobauding, 9
AUXVO, 20, 35
- B**
- baud rate, 9
BOOT, 20, 31
bursts, 26
- C**
- Call Barring, 9
Call Forwarding, 9
Call Hold, 9
Call Waiting, 9
Calling Line Identity, 9
Casing, 8
CE, 18, 56
Cell Broadcast, 9
Class 1, 8, 9
Class 4, 8
Closed User Group, 9
CMOS, 19, 20, 23, 27, 29, 31, 34, 41, 44, 45
column, 21, 44
connector, 7, 10, 12, 19, 22, 27, 29, 31, 32, 33, 34, 35, 36, 38, 39, 40, 41, 44, 45, 46, 47, 48, 49
converter, 34, 35
- D**
- data, 7, 8, 27, 64, 65
Data Carrier Detect, 19, 27
dB, 46, 56
DCS, 7, 16, 26, 46, 48, 55
digital, 12, 34, 44, 52, 66
Digital, 34, 56
dual-band, 7
- E**
- Easy remote control, 8
Echo, 63, 65
EFR, 8, 56
EMC protection, 52
Emergency calls, 8
ESD protection, 52
ETSI, 16, 46, 55
Explicit Call Transfer, 9
- F**
- fax, 7, 8, 9
Fixed Dialling Number, 9
Flash LED, 20
FR, 8, 56
- G**
- gain, 36, 37, 48, 66
general purpose, 19
General Purpose, 19, 20, 34
GND, 25
GND, 19, 20, 21, 22, 25, 27, 41, 43, 56
GPIO, 66
GPRS, 56
Ground plane, 52
GSM, 7, 8, 9, 13, 16, 27, 41, 48, 52, 55, 56
- H**
- handset, 36
hardware, 7, 8, 19, 29, 32, 53
HR, 8, 56
- I**
- I/O, 19, 20, 21, 22, 23, 27, 29, 31, 32, 33, 34, 35, 36, 38, 39, 40, 41, 43, 44, 45
Idle, 26
idle mode, 8
interface, 7, 8, 9, 12, 19, 20, 21, 22, 27, 41, 42, 44, 45, 46, 52

Integra

K

Keyboard, 21, 44

M

MIC1N, 20, 38
MIC1P, 20, 38
MIC2N, 20, 36
MIC2P, 20, 36
microphone, 36, 37, 38, 63
Microphone, 63
Microphone, 20, 36, 37, 38, 52
MMCX (Miniature Micro Connector),
7, 12, 46, 48
MNP2, 9
MO, 9, 56
modem, 7, 8, 10, 12, 13, 14, 15, 16,
18, 25, 28, 37, 44, 46, 48, 49
module, 7, 10, 31
Mounting, 8
MT, 9, 56
Multiparty, 9

N

nominal value, 25

O

OFF, 15, 16, 20, 28, 29, 30
Ohms, 39, 40, 46
ON/~OFF, 20, 28
operating conditions, 23, 27, 29, 31,
32, 33, 34, 35, 36, 38, 39, 40, 41,
44, 45
Operating temperature range, 8

P

PCB, 11
PCS, 7, 46, 48
Performance Test, 16
Phone Book, 64
phonebook, 64
point to point, 9
power, 8, 13, 25, 29, 30, 32, 39, 40,
41, 46, 48, 52
power supply, 25, 41
Power supply, 8, 25

R

radio, 13, 16, 48, 65
Real Time Clock, 9
RF, 7, 10, 12, 13, 14, 15, 16, 17, 19,
46, 48, 52
Ring Indicator, 19, 27

RST, 20, 32, 33, 43

S

serial link, 9, 27, 52
Signal, 27, 29, 31, 32, 33, 34, 35,
36, 38, 39, 40, 41, 43, 44, 45, 63
SIM, 7, 8, 9, 10, 12, 19, 22, 41, 42,
43, 46, 49, 52, 55, 56
SIM Toolkit, 9
SIMCLK, 22, 41, 42, 43
SIMDATA, 22, 41, 42, 43
SIMPRES, 41
SIMRST, 22, 41, 42, 43
SIMVCC, 22, 41, 42, 43
SMS, 7, 8, 9, 56
socket, 22, 41
speaker, 36, 39, 40, 52
Speaker, 19, 20, 39, 40, 63
SPI, 21, 22, 44
SPK1N, 20, 40
SPK1P, 20, 40
Storage temperature, 8

T

Telephony, 8
terminal, 52
Tricodec, 8

U

UCS2, 9
USSD, 9

V

V.42bis, 9
VCC, 20, 21, 22, 43
voice, 7, 63, 66
Volume, 8

W

WAP, 56
Weight, 8
Integra, 1, 3, 6, 7, 10, 11, 13, 16,
17, 18, 28, 29, 31, 32, 34, 46, 52

X

Xmodem, 9

Integra

Figures

figure 1 : mechanical description	10
figure 2 : mechanical description II	11
figure 3 : 50-pin connector.....	22
figure 4 : pin numbering/bottom view	23
figure 5* : level shifter application diagram for serial link.....	26
figure 6 : power OFF procedure 1	27
figure 7 : power OFF procedure 2	27
figure 8 : boot procedure.....	28
figure 9 : reset procedure	29
figure 10 : microphone 2 input.....	33
figure 11 : microphone 1 input.....	34
figure 12 : speaker 2 output.....	35
figure 13 : speaker 1 output.....	36
Figure 14: SIM socket	39
Figure 15: high and low profile CLP connectors.....	42
Figure 16: flexible flat cable	42
Figure 17: flex cable connector	42
Figure 18: MMCX connector example (right angle)	43
Figure 19: Integra demoboard description	45

Tables

Table 1 : Wavecom acceptance test.....	16
Table 2 : 50-pin connector description.....	19
Table 3 : operating conditions.....	21
Table 4 : power supply pin description	23
Table 5 : Power consumption in EGSM mode @ 25°C	24
Table 6 : Power consumption in GSM 1800 and1900 mode @ 25°C.....	24
Table 7 : Serial Link pin description	25
Table 8 : ON / OFF pin description	27
Table 9 : BOOT pin description	28
Table 10 : reset signal pin description.....	29
Table 11 : reset signal electrical characteristics.....	29
Table 12 : reset signal operating conditions.....	30
Table 13 : the flashing LED pin description	30
Table 14 : LED and Integra status	30
Table 15 : General Purpose pin description	31
Table 16 : A/D converter pin description	32
Table 17 : A/D converter electrical characteristics	32
Table 18 : microphone 2 input pin description.....	33
Table 19 : microphone 1 input pin description.....	35
Table 20 : speaker 2 output pin description.....	35
Table 21 : speaker 1 output pin description.....	36
Table 22 : SIM interface pin description.....	37
Table 23 : SIM interface electrical characteristics.....	38
Table 24 : SIM socket pin description	38
Table 25 : SPI Bus pin description.....	39
Table 26 : keypad interface pin description.....	40
Table 27 : radio characteristics	43
Table 28 : climatic and mechanical environment	44

Integra

Table 29 : minimum signals to operate the Integra	47
Table 31 : GSM ETSI recommendations for Phase I and Phase II.	49
Table 30 : AT command list	56

12 Appendix 1

12.1 Mechanical specifications

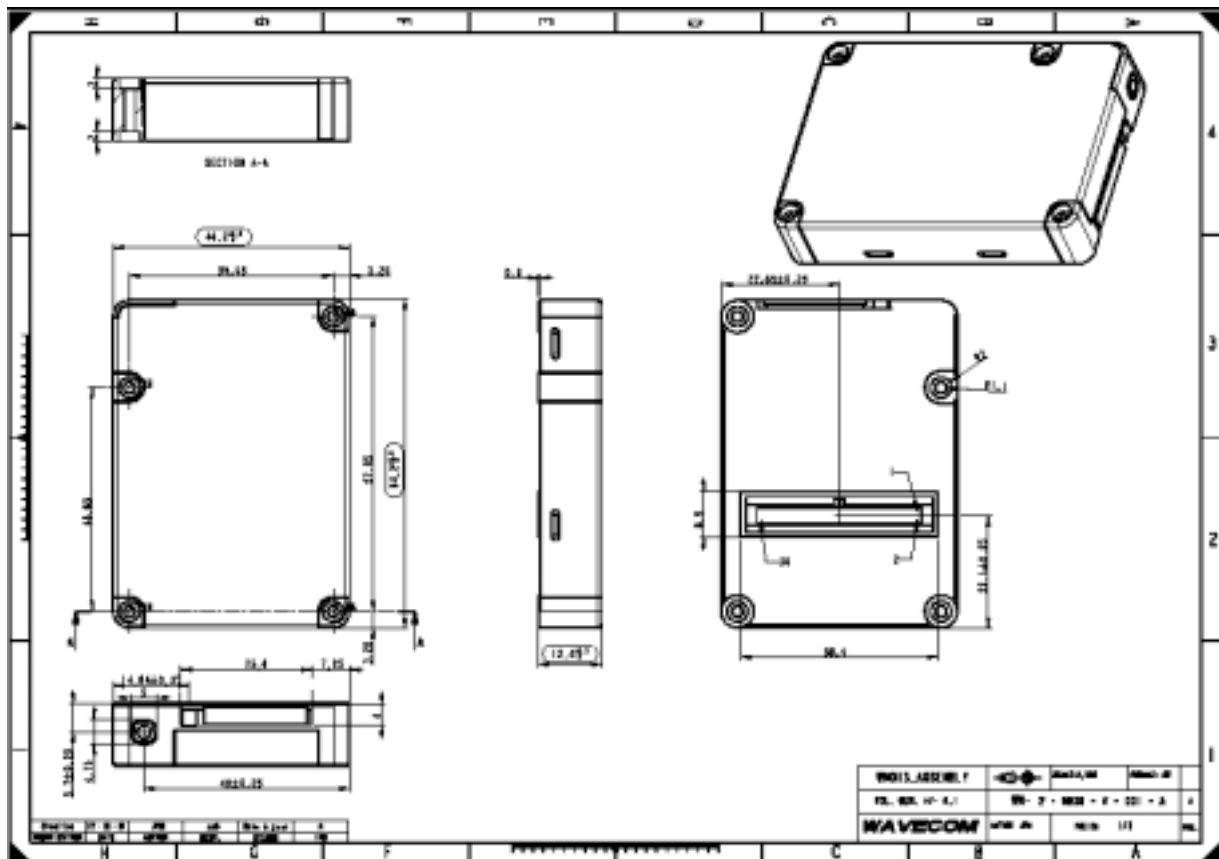

12.2 3V/5V SIM management

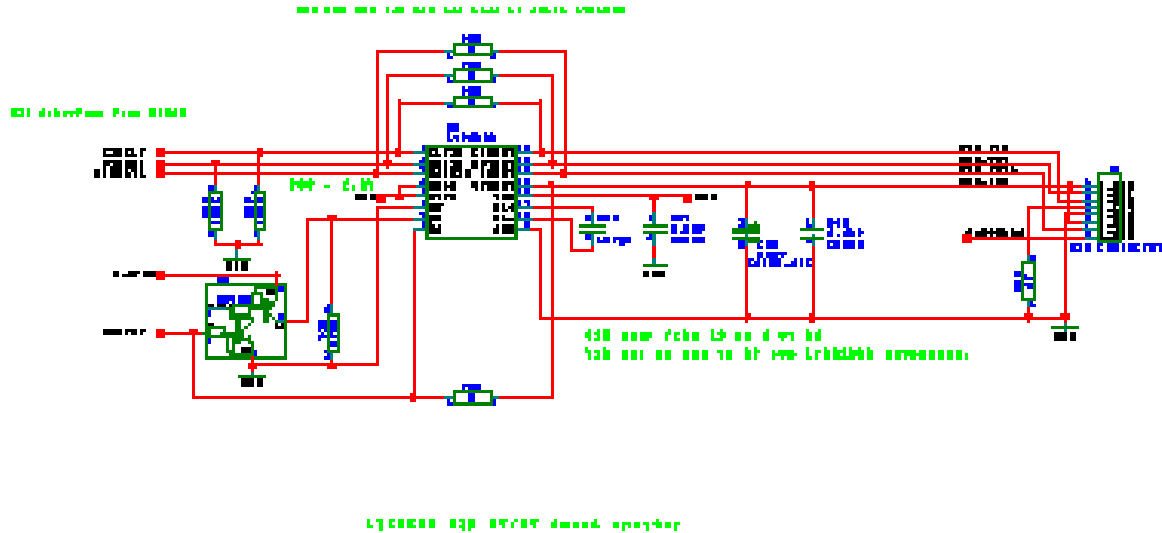

12.3 AT command list

For comprehensive information about AT Commands, please read the AT Commands user's guide

Table 30 : AT command list

General Commands	
+CGMI	Manufacturer Identification
+CGMM	Request Model Identification
+CGMR	Request Revision Identification
+CGSN	Product Serial Number
+CSCS	Select TE Character Set
+CIMI	Request IMSI
+CCID	Card Identification
+GCAP	Capabilities List
A/	Repeat Last Command
+CPOF	Power Off
+CFUN	Set Phone Functionality
+CPAS	Phone Activity Status
+CMEE	Report Mobile Equipment Errors
+CKPD	Keypad Control
+CCLK	Clock management
+CALA	Alarm management

Call Control Commands	
D	Dial command
H	Hang-up Command
A	Answer a Call
+CEER	Extended Error Report
+VTD, +VTS	DTMF Signals
ATDL	Redial Last Telephone Number
AT%Dn	Automatic Dialing (or SMS send) with DTR
ATSO	Automatic Answer
+CICB	Incoming Call Bearer
+VGR, +VGT	Gain Control
+CMUT	Microphone Mute Control
+SPEAKER	Speaker and Microphone Selection
+ECHO	Echo Cancellation
+SIDET	Side Tone Modification
+VIP	Initialize Voice Parameters
+CSNS	Single Numbering Scheme
Network Service Commands	
+CSQ	Signal Quality
+COPS	Operator Selection
+CREG	Network Registration
+WOPN	Read Operator Name
+CPOL	Preferred Operator List
Security Commands	
+CPIN	Enter PIN
+CPIN2	Enter PIN2
+CPINC	PIN Remaining Attempt Number
+CLCK	Facility Lock
+CPWD	Change Password
Phone Book Commands	
+CPBS	Select Phone Book Memory Storage
+CPBR	Read Phone Book Entries
+CPBF	Find Phone Book Entries
+CPBW	White Phone Book Entry
+CPBP	Phone Book Phone Search
+CPBN	Move Action in Phone Book
+CNUM	Subscriber Number
+WAIP	Avoid Phone Book Init

Short Message Commands	
+CSMS	Select Message Service
+CNMA	New Message Acknowledgement
+CPMS	Preferred Message Storage
+CMGF	Preferred Message Format
+CSAS	Save Settings
+CRES	Restore Settings
+CSDH	Show Text Mode parameters
+CNMI	New Message Indication
+CMGR	Read Message
+CMGL	List Message
+CMGS	Send Message
+CMGW	Write Message to Memory
+CMSS	Send Message from Storage
+CSMP	Set Text Mode Parameters
+CMGD	Delete Message
+CSCA	Service Center Address
+CSCB	Select Cell Broadcast Message Types
+WCBM	Cell Broadcast Message Identifiers
+WMSC	Message Status Modification
+WMGO	Message Overwriting
Supplementary Services Commands	
+CCFC	Call Forwarding
+CLCK	Call Barring
+CPWD	Modify SS Password
+CCWA	Call Waiting
+CLIR	Calling Line Identification Restriction
+CLIP	Calling Line Identification Presentation
+COLP	Connected Line Identification Presentation
+CAOC	Advice Of Charge
+CACM	AccumulatedCcall Meter
+CAMM	Accumulated Call Meter Maximum
+CPUC	Price Per Unit and Currency Table
+CHLD	Call Related Supplementary Services
+CLCC	List Current Calls
+CSSN	Supplementary Service Notifications
+CUSD	Unstructured Supplementary Service Data
+CCUG	Closed User Group
Data Commands	
+CBST	Bearer Type Selection
+FCLASS	Select Mode
+CR	Service Reporting Control
+CRC	Cellular Result Codes
+ILRR	DTE-DCE Local Rate Reporting
+CRLP	Radio Link Protocol Parameters
+DOPT	Others Radio Link Parameters
%C	Select Data Compression
+DS	V42 bis Data Compression
+DR	V42 bis Data Compression Report
\N	Select Data Error Correcting Mode

Fax Commands	
+FTM	Transmit Speed
+FRM	Receive Speed
+FTH	HDLC Transmit Speed
+FRH	HDLC Receive Speed
+FTS	Stop Transmission and Wait
+FRS	Receive Silence
Fax Class 2 Commands	
+FDT	Transmit Data
+FDR	Receive Data
+FET	Transmit Page Punctuation
+FPTS	Page Transfer Status Parameters
+FK	Terminate Session
+FBOR	Page Transfer Bit Order
+FBUF	Buffer Size Report
+FCQ	Copy Quality Checking
+FCR	Capability to Receive
+FDIS	Current Sessions Parameters
+FDCC	DCE Capabilities Parameters
+FLID	Local ID String
+FPHCTO	Page Transfer Timeout Parameter
V24-V25 Commands	
+IPR	Fixed DTE Rate
+ICF	DTE-DCE Character Framing
+IFC	DTE-DCE Local Flow Control
&C	Set DCD Signal
&D	Set DTR Signal
&S	Set DSR Signal
O	Back to Online Mode
Q	Result Code Suppression
V	DCE Response Format
Z	Default Configuration
&W	Save Configuration
&T	Auto-Tests
E	Echo
&F	Restore Factory Settings
&V	Display Configuration
I	Request Identification Information
SIM Toolkit Commands	
+STSF	SIM Toolkit Set Facilities
+STIN	SIM Toolkit Indication
+STGI	SIM Toolkit Get Information
+STCR	SIM Toolkit Control Response
+STGR	SIM Toolkit Give Response

Specific AT Commands	
+CCED	Cell Environment Description
+CCED	Automatic RxLev Indication
+WIND	General Indications
+ADC	Analog Digital Converters Measurements
+CMER	Mobile Equipment Event Reporting
+WLPR	Read Language Preference
+WLPW	Write Language Preference
+WIOR	Read GPIO Value
+WIOV	Write GPIO Value
+WAC	Abort Command
+WTONE	Play Tone
+WDTMF	Play DTMF Tone
+WDWL	Wavecom Downloading
+WVR	Wavecom Voice Rate
+WDR	Data Rate
+WHWV	Hardware Version
+WDOP	Date Of Production
+WSVG	Wavecom Select Voice Gain
+WSTR	Wavecom Status Request
+WSCAN	Wavecom Scan
+WRIM	Ring Indicator Mode
+W32K	Power saving mode

Integra

FACTSHEET F-2001

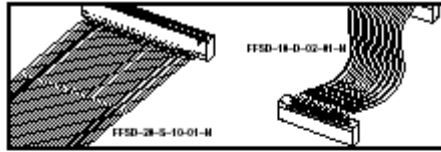

.050" (1,27mm) CABLE STRIPS FFSD SERIES

Make with:
FTS, FTSH

Features:

- Pin/finger contacts optimize normal, insertion and withdrawal forces
- Low profile, only 5mm (.200") assembled height
- Making terminal strip with keying/shroud available (FTSH Series)
- Other sizes available

Specifications:

FFSD
Insulator Material: Black Glass Filled Polyamide
Contact: Nickel
Operating Rating: 0.5A
Operating Temp Range: -80°C to +105°C
Flaring: 50° (0.25mm) Au over 50μ" (1.27mm) Ni on contact area, 500μ" (0.02mm) Sn over 50μ" (1.27mm) Ni on balance
Lead Side Accepts: 0.41mm (0.016")
Contact To Mate: 30 mil maximum
Insulator Depth: 0.64mm (0.025") to 0.81mm (0.032")
Wire: 30 AWG



See FTSH Series for making leader with keying/shroud

TYPE STRIP	NO. PINS PER ROW	END OPTION	OVERALL LENGTH	01	N	OTHER OPTION
	-05, -10, -13, -17, -20, -25 (Call for other sizes)	-S = Single End -D = Double End	"XX" = Assembled Length		-N = Notch Polarization	-RW = Reverse Wiring
<p>FFSD - Socket Strip</p>						
<p>APPLICATIONS</p>						
					-R = Reversed	-M = Mill Edge Reverse
						-O = Double Reverse

Note: This Series is not standard, non-reusable

Integra

FACTSHEET F-200

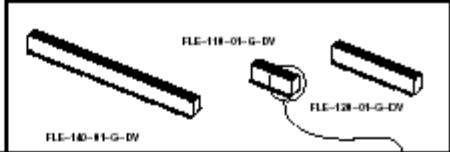

STANDARD SOCKET FLE SERIES

SPECIFICATIONS

Materials:
 Back Lead: Metal Polymer
 Contact Material:
 Phosphor Bronze
 Current Rating:
 1.75A @ 80°C ambient
 Operating Temp Range:
 -55°C to +125°C
Plating:
 Au over 10µ" (0.25µm) Ni
 Contact Resistance:
 100mΩ max
Insulation Depth:
 (1.0mm) .002" to
 (1.20mm) .022" with
 (0.38mm) .015" or
 (0.50mm) .020" or
 (0.63mm) .025" or
 (0.76mm) .030" or
 (0.89mm) .035" or
 (1.02mm) .040" or
 (1.15mm) .045" or
 (1.28mm) .050" or
 (1.41mm) .055" or
 (1.54mm) .060" or
 (1.67mm) .065" or
 (1.80mm) .070" or
 (1.93mm) .075" or
 (2.06mm) .080" or
 (2.19mm) .085" or
 (2.32mm) .090" or
 (2.45mm) .095" or
 (2.58mm) .100" or
 (2.71mm) .105" or
 (2.84mm) .110" or
 (2.97mm) .115" or
 (3.10mm) .120" or
 (3.23mm) .125" or
 (3.36mm) .130" or
 (3.49mm) .135" or
 (3.62mm) .140" or
 (3.75mm) .145" or
 (3.88mm) .150" or
 (4.01mm) .155" or
 (4.14mm) .160" or
 (4.27mm) .165" or
 (4.40mm) .170" or
 (4.53mm) .175" or
 (4.66mm) .180" or
 (4.79mm) .185" or
 (4.92mm) .190" or
 (5.05mm) .195" or
 (5.18mm) .200" or
 (5.31mm) .205" or
 (5.44mm) .210" or
 (5.57mm) .215" or
 (5.70mm) .220" or
 (5.83mm) .225" or
 (5.96mm) .230" or
 (6.09mm) .235" or
 (6.22mm) .240" or
 (6.35mm) .245" or
 (6.48mm) .250" or
 (6.61mm) .255" or
 (6.74mm) .260" or
 (6.87mm) .265" or
 (7.00mm) .270" or
 (7.13mm) .275" or
 (7.26mm) .280" or
 (7.39mm) .285" or
 (7.52mm) .290" or
 (7.65mm) .295" or
 (7.78mm) .300" or
 (7.91mm) .305" or
 (8.04mm) .310" or
 (8.17mm) .315" or
 (8.30mm) .320" or
 (8.43mm) .325" or
 (8.56mm) .330" or
 (8.69mm) .335" or
 (8.82mm) .340" or
 (8.95mm) .345" or
 (9.08mm) .350" or
 (9.21mm) .355" or
 (9.34mm) .360" or
 (9.47mm) .365" or
 (9.60mm) .370" or
 (9.73mm) .375" or
 (9.86mm) .380" or
 (9.99mm) .385" or
 (10.12mm) .390" or
 (10.25mm) .395" or
 (10.38mm) .400" or
 (10.51mm) .405" or
 (10.64mm) .410" or
 (10.77mm) .415" or
 (10.90mm) .420" or
 (11.03mm) .425" or
 (11.16mm) .430" or
 (11.29mm) .435" or
 (11.42mm) .440" or
 (11.55mm) .445" or
 (11.68mm) .450" or
 (11.81mm) .455" or
 (11.94mm) .460" or
 (12.07mm) .465" or
 (12.20mm) .470" or
 (12.33mm) .475" or
 (12.46mm) .480" or
 (12.59mm) .485" or
 (12.72mm) .490" or
 (12.85mm) .495" or
 (12.98mm) .500" or
 (13.11mm) .505" or
 (13.24mm) .510" or
 (13.37mm) .515" or
 (13.50mm) .520" or
 (13.63mm) .525" or
 (13.76mm) .530" or
 (13.89mm) .535" or
 (14.02mm) .540" or
 (14.15mm) .545" or
 (14.28mm) .550" or
 (14.41mm) .555" or
 (14.54mm) .560" or
 (14.67mm) .565" or
 (14.80mm) .570" or
 (14.93mm) .575" or
 (15.06mm) .580" or
 (15.19mm) .585" or
 (15.32mm) .590" or
 (15.45mm) .595" or
 (15.58mm) .600" or
 (15.71mm) .605" or
 (15.84mm) .610" or
 (15.97mm) .615" or
 (16.10mm) .620" or
 (16.23mm) .625" or
 (16.36mm) .630" or
 (16.49mm) .635" or
 (16.62mm) .640" or
 (16.75mm) .645" or
 (16.88mm) .650" or
 (17.01mm) .655" or
 (17.14mm) .660" or
 (17.27mm) .665" or
 (17.40mm) .670" or
 (17.53mm) .675" or
 (17.66mm) .680" or
 (17.79mm) .685" or
 (17.92mm) .690" or
 (18.05mm) .695" or
 (18.18mm) .700" or
 (18.31mm) .705" or
 (18.44mm) .710" or
 (18.57mm) .715" or
 (18.70mm) .720" or
 (18.83mm) .725" or
 (18.96mm) .730" or
 (19.09mm) .735" or
 (19.22mm) .740" or
 (19.35mm) .745" or
 (19.48mm) .750" or
 (19.61mm) .755" or
 (19.74mm) .760" or
 (19.87mm) .765" or
 (20.00mm) .770" or
 (20.13mm) .775" or
 (20.26mm) .780" or
 (20.39mm) .785" or
 (20.52mm) .790" or
 (20.65mm) .795" or
 (20.78mm) .800" or
 (20.91mm) .805" or
 (21.04mm) .810" or
 (21.17mm) .815" or
 (21.30mm) .820" or
 (21.43mm) .825" or
 (21.56mm) .830" or
 (21.69mm) .835" or
 (21.82mm) .840" or
 (21.95mm) .845" or
 (22.08mm) .850" or
 (22.21mm) .855" or
 (22.34mm) .860" or
 (22.47mm) .865" or
 (22.60mm) .870" or
 (22.73mm) .875" or
 (22.86mm) .880" or
 (22.99mm) .885" or
 (23.12mm) .890" or
 (23.25mm) .895" or
 (23.38mm) .900" or
 (23.51mm) .905" or
 (23.64mm) .910" or
 (23.77mm) .915" or
 (23.90mm) .920" or
 (24.03mm) .925" or
 (24.16mm) .930" or
 (24.29mm) .935" or
 (24.42mm) .940" or
 (24.55mm) .945" or
 (24.68mm) .950" or
 (24.81mm) .955" or
 (24.94mm) .960" or
 (25.07mm) .965" or
 (25.20mm) .970" or
 (25.33mm) .975" or
 (25.46mm) .980" or
 (25.59mm) .985" or
 (25.72mm) .990" or
 (25.85mm) .995" or
 (25.98mm) 1.000" or
 (26.11mm) 1.005" or
 (26.24mm) 1.010" or
 (26.37mm) 1.015" or
 (26.50mm) 1.020" or
 (26.63mm) 1.025" or
 (26.76mm) 1.030" or
 (26.89mm) 1.035" or
 (27.02mm) 1.040" or
 (27.15mm) 1.045" or
 (27.28mm) 1.050" or
 (27.41mm) 1.055" or
 (27.54mm) 1.060" or
 (27.67mm) 1.065" or
 (27.80mm) 1.070" or
 (27.93mm) 1.075" or
 (28.06mm) 1.080" or
 (28.19mm) 1.085" or
 (28.32mm) 1.090" or
 (28.45mm) 1.095" or
 (28.58mm) 1.100" or
 (28.71mm) 1.105" or
 (28.84mm) 1.110" or
 (28.97mm) 1.115" or
 (29.10mm) 1.120" or
 (29.23mm) 1.125" or
 (29.36mm) 1.130" or
 (29.49mm) 1.135" or
 (29.62mm) 1.140" or
 (29.75mm) 1.145" or
 (29.88mm) 1.150" or
 (30.01mm) 1.155" or
 (30.14mm) 1.160" or
 (30.27mm) 1.165" or
 (30.40mm) 1.170" or
 (30.53mm) 1.175" or
 (30.66mm) 1.180" or
 (30.79mm) 1.185" or
 (30.92mm) 1.190" or
 (31.05mm) 1.195" or
 (31.18mm) 1.200" or
 (31.31mm) 1.205" or
 (31.44mm) 1.210" or
 (31.57mm) 1.215" or
 (31.70mm) 1.220" or
 (31.83mm) 1.225" or
 (31.96mm) 1.230" or
 (32.09mm) 1.235" or
 (32.22mm) 1.240" or
 (32.35mm) 1.245" or
 (32.48mm) 1.250" or
 (32.61mm) 1.255" or
 (32.74mm) 1.260" or
 (32.87mm) 1.265" or
 (33.00mm) 1.270" or
 (33.13mm) 1.275" or
 (33.26mm) 1.280" or
 (33.39mm) 1.285" or
 (33.52mm) 1.290" or
 (33.65mm) 1.295" or
 (33.78mm) 1.300" or
 (33.91mm) 1.305" or
 (34.04mm) 1.310" or
 (34.17mm) 1.315" or
 (34.30mm) 1.320" or
 (34.43mm) 1.325" or
 (34.56mm) 1.330" or
 (34.69mm) 1.335" or
 (34.82mm) 1.340" or
 (34.95mm) 1.345" or
 (35.08mm) 1.350" or
 (35.21mm) 1.355" or
 (35.34mm) 1.360" or
 (35.47mm) 1.365" or
 (35.60mm) 1.370" or
 (35.73mm) 1.375" or
 (35.86mm) 1.380" or
 (35.99mm) 1.385" or
 (36.12mm) 1.390" or
 (36.25mm) 1.395" or
 (36.38mm) 1.400" or
 (36.51mm) 1.405" or
 (36.64mm) 1.410" or
 (36.77mm) 1.415" or
 (36.90mm) 1.420" or
 (37.03mm) 1.425" or
 (37.16mm) 1.430" or
 (37.29mm) 1.435" or
 (37.42mm) 1.440" or
 (37.55mm) 1.445" or
 (37.68mm) 1.450" or
 (37.81mm) 1.455" or
 (37.94mm) 1.460" or
 (38.07mm) 1.465" or
 (38.20mm) 1.470" or
 (38.33mm) 1.475" or
 (38.46mm) 1.480" or
 (38.59mm) 1.485" or
 (38.72mm) 1.490" or
 (38.85mm) 1.495" or
 (38.98mm) 1.500" or
 (39.11mm) 1.505" or
 (39.24mm) 1.510" or
 (39.37mm) 1.515" or
 (39.50mm) 1.520" or
 (39.63mm) 1.525" or
 (39.76mm) 1.530" or
 (39.89mm) 1.535" or
 (40.02mm) 1.540" or
 (40.15mm) 1.545" or
 (40.28mm) 1.550" or
 (40.41mm) 1.555" or
 (40.54mm) 1.560" or
 (40.67mm) 1.565" or
 (40.80mm) 1.570" or
 (40.93mm) 1.575" or
 (41.06mm) 1.580" or
 (41.19mm) 1.585" or
 (41.32mm) 1.590" or
 (41.45mm) 1.595" or
 (41.58mm) 1.600" or
 (41.71mm) 1.605" or
 (41.84mm) 1.610" or
 (41.97mm) 1.615" or
 (42.10mm) 1.620" or
 (42.23mm) 1.625" or
 (42.36mm) 1.630" or
 (42.49mm) 1.635" or
 (42.62mm) 1.640" or
 (42.75mm) 1.645" or
 (42.88mm) 1.650" or
 (43.01mm) 1.655" or
 (43.14mm) 1.660" or
 (43.27mm) 1.665" or
 (43.40mm) 1.670" or
 (43.53mm) 1.675" or
 (43.66mm) 1.680" or
 (43.79mm) 1.685" or
 (43.92mm) 1.690" or
 (44.05mm) 1.695" or
 (44.18mm) 1.700" or
 (44.31mm) 1.705" or
 (44.44mm) 1.710" or
 (44.57mm) 1.715" or
 (44.70mm) 1.720" or
 (44.83mm) 1.725" or
 (44.96mm) 1.730" or
 (45.09mm) 1.735" or
 (45.22mm) 1.740" or
 (45.35mm) 1.745" or
 (45.48mm) 1.750" or
 (45.61mm) 1.755" or
 (45.74mm) 1.760" or
 (45.87mm) 1.765" or
 (46.00mm) 1.770" or
 (46.13mm) 1.775" or
 (46.26mm) 1.780" or
 (46.39mm) 1.785" or
 (46.52mm) 1.790" or
 (46.65mm) 1.795" or
 (46.78mm) 1.800" or
 (46.91mm) 1.805" or
 (47.04mm) 1.810" or
 (47.17mm) 1.815" or
 (47.30mm) 1.820" or
 (47.43mm) 1.825" or
 (47.56mm) 1.830" or
 (47.69mm) 1.835" or
 (47.82mm) 1.840" or
 (47.95mm) 1.845" or
 (48.08mm) 1.850" or
 (48.21mm) 1.855" or
 (48.34mm) 1.860" or
 (48.47mm) 1.865" or
 (48.60mm) 1.870" or
 (48.73mm) 1.875" or
 (48.86mm) 1.880" or
 (48.99mm) 1.885" or
 (49.12mm) 1.890" or
 (49.25mm) 1.895" or
 (49.38mm) 1.900" or
 (49.51mm) 1.905" or
 (49.64mm) 1.910" or
 (49.77mm) 1.915" or
 (49.90mm) 1.920" or
 (50.03mm) 1.925" or
 (50.16mm) 1.930" or
 (50.29mm) 1.935" or
 (50.42mm) 1.940" or
 (50.55mm) 1.945" or
 (50.68mm) 1.950" or
 (50.81mm) 1.955" or
 (50.94mm) 1.960" or
 (51.07mm) 1.965" or
 (51.20mm) 1.970" or
 (51.33mm) 1.975" or
 (51.46mm) 1.980" or
 (51.59mm) 1.985" or
 (51.72mm) 1.990" or
 (51.85mm) 1.995" or
 (51.98mm) 2.000" or
 (52.11mm) 2.005" or
 (52.24mm) 2.010" or
 (52.37mm) 2.015" or
 (52.50mm) 2.020" or
 (52.63mm) 2.025" or
 (52.76mm) 2.030" or
 (52.89mm) 2.035" or
 (53.02mm) 2.040" or
 (53.15mm) 2.045" or
 (53.28mm) 2.050" or
 (53.41mm) 2.055" or
 (53.54mm) 2.060" or
 (53.67mm) 2.065" or
 (53.80mm) 2.070" or
 (53.93mm) 2.075" or
 (54.06mm) 2.080" or
 (54.19mm) 2.085" or
 (54.32mm) 2.090" or
 (54.45mm) 2.095" or
 (54.58mm) 2.100" or
 (54.71mm) 2.105" or
 (54.84mm) 2.110" or
 (54.97mm) 2.115" or
 (55.10mm) 2.120" or
 (55.23mm) 2.125" or
 (55.36mm) 2.130" or
 (55.49mm) 2.135" or
 (55.62mm) 2.140" or
 (55.75mm) 2.145" or
 (55.88mm) 2.150" or
 (56.01mm) 2.155" or
 (56.14mm) 2.160" or
 (56.27mm) 2.165" or
 (56.40mm) 2.170" or
 (56.53mm) 2.175" or
 (56.66mm) 2.180" or
 (56.79mm) 2.185" or
 (56.92mm) 2.190" or
 (57.05mm) 2.195" or
 (57.18mm) 2.200" or
 (57.31mm) 2.205" or
 (57.44mm) 2.210" or
 (57.57mm) 2.215" or
 (57.70mm) 2.220" or
 (57.83mm) 2.225" or
 (57.96mm) 2.230" or
 (58.09mm) 2.235" or
 (58.22mm) 2.240" or
 (58.35mm) 2.245" or
 (58.48mm) 2.250" or
 (58.61mm) 2.255" or
 (58.74mm) 2.260" or
 (58.87mm) 2.265" or
 (59.00mm) 2.270" or
 (59.13mm) 2.275" or
 (59.26mm) 2.280" or
 (59.39mm) 2.285" or
 (59.52mm) 2.290" or
 (59.65mm) 2.295" or
 (59.78mm) 2.300" or
 (59.91mm) 2.305" or
 (60.04mm) 2.310" or
 (60.17mm) 2.315" or
 (60.30mm) 2.320" or
 (60.43mm) 2.325" or
 (60.56mm) 2.330" or
 (60.69mm) 2.335" or
 (60.82mm) 2.340" or
 (60.95mm) 2.345" or
 (61.08mm) 2.350" or
 (61.21mm) 2.355" or
 (61.34mm) 2.360" or
 (61.47mm) 2.365" or
 (61.60mm) 2.370" or
 (61.73mm) 2.375" or
 (61.86mm) 2.380" or
 (61.99mm) 2.385" or
 (62.12mm) 2.390" or
 (62.25mm) 2.395" or
 (62.38mm) 2.400" or
 (62.51mm) 2.405" or
 (62.64mm) 2.410" or
 (62.77mm) 2.415" or
 (62.90mm) 2.420" or
 (63.03mm) 2.425" or
 (63.16mm) 2.430" or
 (63.29mm) 2.435" or
 (63.42mm) 2.440" or
 (63.55mm) 2.445" or
 (63.68mm) 2.450" or
 (63.81mm) 2.455" or
 (63.94mm) 2.460" or
 (64.07mm) 2.465" or
 (64.20mm) 2.470" or
 (64.33mm) 2.475" or
 (64.46mm) 2.480" or
 (64.59mm) 2.485" or
 (64.72mm) 2.490" or
 (64.85mm) 2.495" or
 (64.98mm) 2.500" or
 (65.11mm) 2.505" or
 (65.24mm) 2.510" or
 (65.37mm) 2.515" or
 (65.50mm) 2.520" or
 (65.63mm) 2.525" or
 (65.76mm) 2.530" or
 (65.89mm) 2.535" or
 (66.02mm) 2.540" or
 (66.15mm) 2.545" or
 (66.28mm) 2.550" or
 (66.41mm) 2.555" or
 (66.54mm) 2.560" or
 (66.67mm) 2.565" or
 (66.80mm) 2.570" or
 (66.93mm) 2.575" or
 (67.06mm) 2.580" or
 (67.19mm) 2.585" or
 (67.32mm) 2.590" or
 (67.45mm) 2.595" or
 (67.58mm) 2.600" or
 (67.71mm) 2.605" or
 (67.84mm) 2.610" or
 (67.97mm) 2.615" or
 (68.10mm) 2.620" or
 (68.23mm) 2.625" or
 (68.36mm) 2.630" or
 (68.49mm) 2.635" or
 (68.62mm) 2.640" or
 (68.75mm) 2.645" or
 (68.88mm) 2.650" or
 (69.01mm) 2.655" or
 (69.14mm) 2.660" or
 (69.27mm) 2.665" or
 (69.40mm) 2.670" or
 (69.53mm) 2.675" or
 (69.66mm) 2.680" or
 (69.79mm) 2.685" or
 (69.92mm) 2.690" or
 (70.05mm) 2.695" or
 (70.18mm) 2.700" or
 (70.31mm) 2.705" or
 (70.44mm) 2.710" or
 (70.57mm) 2.715" or
 (70.70mm) 2.720" or
 (70.83mm) 2.725" or
 (70.96mm) 2.730" or
 (71.09mm) 2.735" or
 (71.22mm) 2.740" or
 (71.35mm) 2.745" or
 (71.48mm) 2.750" or
 (71.61mm) 2.755" or
 (71.74mm) 2.760" or
 (71.87mm) 2.765" or
 (72.00mm) 2.770" or
 (72.13mm) 2.775" or
 (72.26mm) 2.780" or
 (72.39mm) 2.785" or
 (72.52mm) 2.790" or
 (72.65mm) 2.795" or
 (72.78mm) 2.800" or
 (72.91mm) 2.805" or
 (73.04mm) 2.810" or
 (73.17mm) 2.815" or
 (73.30mm) 2.820" or
 (73.43mm) 2.825" or
 (73.56mm) 2.830" or
 (73.69mm) 2.835" or
 (73.82mm) 2.840" or
 (73.95mm) 2.845" or
 (74.08mm) 2.850" or
 (74.21mm) 2.855" or
 (74.34mm) 2.860" or
 (74.47mm) 2.865" or
 (74.60mm) 2.870" or
 (74.73mm) 2.875" or
 (74.86mm) 2.880" or
 (74.99mm) 2.885" or
 (75.12mm) 2.890" or
 (75.25mm) 2.895" or
 (75.38mm) 2.900" or
 (75.51mm) 2.905" or
 (75.64mm) 2.910" or
 (75.77mm) 2.915" or
 (75.90mm) 2.920" or
 (76.03mm) 2.925" or
 (76.16mm) 2.930" or
 (76.29mm) 2.935" or
 (76.42mm) 2.940" or
 (76.55mm) 2.945" or
 (76.68mm) 2.950" or
 (76.81mm) 2.955" or
 (76.94mm) 2.960" or
 (77.07mm) 2.965" or
 (77.20mm) 2.970" or
 (77.33mm) 2.975" or
 (77.46mm) 2.980" or
 (77.59mm) 2.985" or
 (77.72mm) 2.990" or
 (77.85mm) 2.995" or
 (77.98mm) 3.000" or
 (78.11mm) 3.005" or
 (78.24mm) 3.010" or
 (78.37mm) 3.015" or
 (78.50mm) 3.020" or
 (78.63mm) 3.025" or
 (78.76mm) 3.030" or
 (78.89mm) 3.035" or
 (79.02mm) 3.040" or
 (79.15mm) 3.045" or
 (79.28mm) 3.050" or
 (79.41mm) 3.055" or
 (79.54mm) 3.060" or
 (79.67mm) 3.065" or
 (79.80mm) 3.0

13 Appendix 2

13.1 RF Exposures

Pursuant to 47 CFR § 24.52 of the FCC Rules and Regulations, personal communications services (PCS) equipment is subject to the radio frequency radiation exposure requirements specified in § 1.1307(b), § 2.1091 and § 2.1093 as appropriate.

The Wavecom Modem is a GSM (PCS 1900) terminal which operates in the US licensed PCS frequency spectrum. The device transmits over the 1850-1910 MHz band and receives over the 1930-1990 MHz Band. Wavecom, Inc. certifies that it has determined that the Modem complies with the RF hazard requirements applicable to broadband PCS equipment operating under the authority of 47 CFR Part 24, Subpart E of the FCC Rules and Regulations. This determination is dependent upon installation, operation and use of the equipment in accordance with all instructions provided.

The Modem is designed for and intended to be used in fixed and mobile applications. "Fixed" means that the device is physically secured at one location and is not able to be easily moved to another location. "Mobile" means that the device is designed to be used in other than fixed locations and generally in such a way that a separation distance of at least 20 cm is normally maintained between the transmitter's antenna and the body of the user or nearby persons. The Modem is not designed for or intended to be used in portable applications (within 20 cm of the body of the user) and such uses are strictly prohibited. To ensure that the unit complies with current FCC regulations limiting both maximum RF output power and human exposure to radio frequency radiation, a separation distance of at least 20 cm must be maintained between the unit's antenna and the body of the user and any nearby persons at all times and in all applications and uses. Additionally, in mobile applications, maximum antenna gain must not exceed 3 dBi (to comply with Section 24.232(b) and is limited to 7 dBi for fixed applications. Finally, the tune-up procedure for the O9EM2113 ensures that the maximum RF output power of the device does not exceed 30.0 dBm within the variations that can be expected due to quantity production and testing on a statistical basis.

13.2 Instructions to OEM

Wavecom User's manual includes specific warnings and cautions in order to ensure that OEMs are aware of their responsibilities, with regards to RF exposure compliance, for products into which the modem is integrated. With this guidance, the OEM will be able to incorporate into their documentation the necessary operating conditions and warnings.

OEMs need to provide a manual with the "final" product that clearly states the operating requirements and conditions and that these must be observed to ensure compliance with current FCC RF exposure requirements / MPE limits (refer to chapter 13. RF exposure instructions). This will enable the OEM to generate (and provide the end-user with) the appropriate operating instructions, warnings and cautions, and/or markings for their product.